



MANUFACTURING INC.

**OWNER'S MANUAL**

**ABSORBENT  
CASE CODER PRINTERS  
CA-SERIES**

**INSTALLATION - OPERATION - MAINTENANCE**

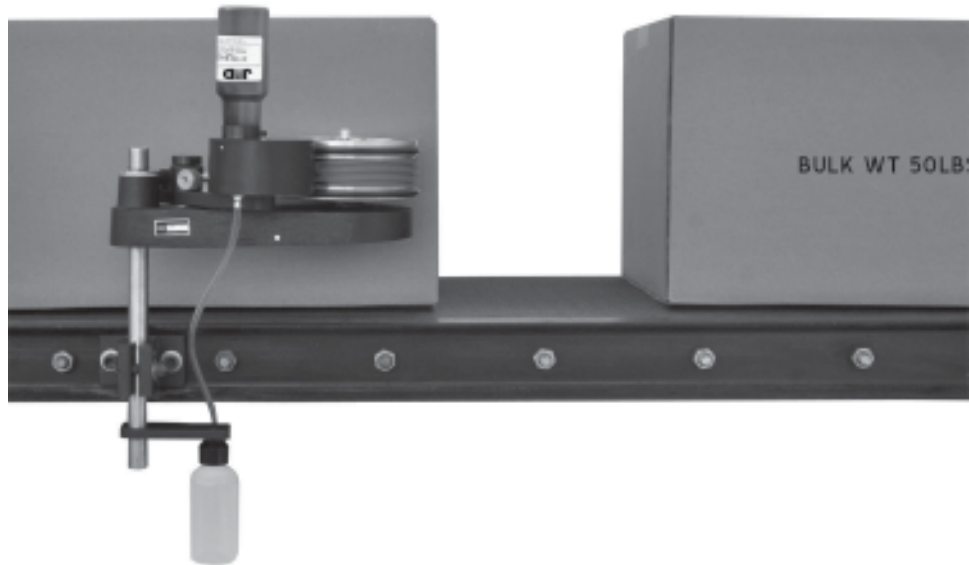

**JMD Manufacturing Inc.**

59 Fountain Street Framingham, MA 01702 USA

Ph: (508) 620-6563 Fax: (508) 620-7563 Website: <http://www.jmdmfg.com>

1-800-752-5JMD (563)

**PCase-10019**

---

---

## **IMPORTANT NOTE**

---

---

JMD products are manufactured to exacting standards and every available step has been taken to assure your complete satisfaction. It is most important, however, that the instructions contained in this manual are read and carefully followed for best results. Failure to do so may result in unsatisfactory performance, damage to the equipment and personal injury.

### **TABLE OF CONTENTS**

PREFACE . . . . .	3
<b>SPECIFICATIONS</b>	
CA-118 Series . . . . .	4
CA-218 Series . . . . .	5
CA-318 Series . . . . .	6
CA-418 Series . . . . .	7
Reset & Continuous Models . . . . .	8
Mounting Configuration . . . . .	8
Printing Dies . . . . .	9
Metric Printing Dies . . . . .	9
Ink Rolls . . . . .	10
<b>QUICK START</b>	
Pre-inking Microcell Rolls . . . . .	11
Installing the Pre-inked Roll . . . . .	12
Installing the Printing Dies . . . . .	13
Optional Type Blocking Kit . . . . .	13
Adjusting the Ink Roll / Die Face Contact Pressure . . . . .	14
Reservoir Roll Covers & 4 oz. Reservoir Ink Cartridges . . . . .	15
<b>CARTON PRINTING</b>	
Carton Alignment . . . . .	16
Setting the Spring Tension Mechanism . . . . .	17
Die Positioning for Indexing Applications . . . . .	18
<b>MAINTENANCE</b>	
Cleaning the Coder / Cleaning Dies . . . . .	19
Pre-Inking Neoprene & XF Neoprene Foam Rolls . . . . .	20
<b>MOUNTING CONFIGURATION CONVERSION</b>	
Left Hand / Right Hand / Field Conversion . . . . .	21
Pivot Arm Assembly Conversion . . . . .	21
Tension Arm Assembly Conversion . . . . .	22
Print Drum Index Mechanism Conversion . . . . .	23
Replacing Print Drum Index Springs . . . . .	25
Removing & Replacing Index Block "B" . . . . .	26
PARTS DIAGRAMS AND PARTS LISTS . . . . .	28

#### **- LIMITED WARRANTY -**

JMD Case Coder Printers are guaranteed to be free from defects in materials and workmanship for a period of 90 days from the date of purchase. Components found to be defective during this time will be repaired free of charge if returned to the factory. Damage resulting from use of improper inks, improper installation, or operation is not covered under the scope of this warranty. For warranty service please contact our Customer Service Department.

---

---

## ***PREFACE***

---

---

The JMD Case Coder Printer has been designed to print lot numbers, date codes, and text information on cartons, web materials, and other conveyed products. JMD Case Coders are precision engineered to give years of reliable service under the most demanding conditions.

## ***FEATURES***

- 1- **Reset (spot printing) and continuous (continuous printing) models with print areas up to 3-15/16" x 17-1/2".**
- 2- **JMD's die system allows text information to be set using individual characters or one piece logo dies.**
- 3 - **Custom logo dies can also be produced from camera ready copy.**
- 4 - **Field convertible mounting configuration for printing on the top, side, or bottom of the product.**
- 5 - **Precision machined, impact resistant aluminum castings.**
- 6 - **Baseplate casting has polyurethane finish for corrosion resistance.**
- 7 - **Permanently lubricated, sealed ball bearings which provide for extremely accurate, low friction drum rotation.**
- 8 - **Stainless steel mounting columns and shafts for durability even in harsh environments.**
- 9 - **Reset mechanism with dual compression springs mounted over stainless steel guide rods minimizes spring breakage and provides unsurpassed reset speed and accuracy.**
- 10 - **Optional reservoir inking system which automatically feeds ink to the ink roll during operation.**

**Patented disposable ink cartridges eliminate liquid ink mess and unnecessary down time.**

**\*U.S. Patent No. 4,552,063**

## ***QUICK START*** ***SEE PAGE 11***

This manual was written with a full understanding that very few people like to read manuals or have the time to do so. To accommodate those who have little time to spare we have included a Quick Start section which will get your coder operating in just a few minutes.

## ***CODER SPECIFICATIONS***

The specification section includes drawings with the basic dimensions of the coders, the net weights, maximum die capacities, maximum print width and print drum circumferences. This section also lists the specifications for the printing dies and an explanation of the reset and continuous models and the various mounting configurations.

# ABSORBENT CASE CODER PRINTER SPECIFICATIONS CA-118 SERIES

Model Shown: CA-118

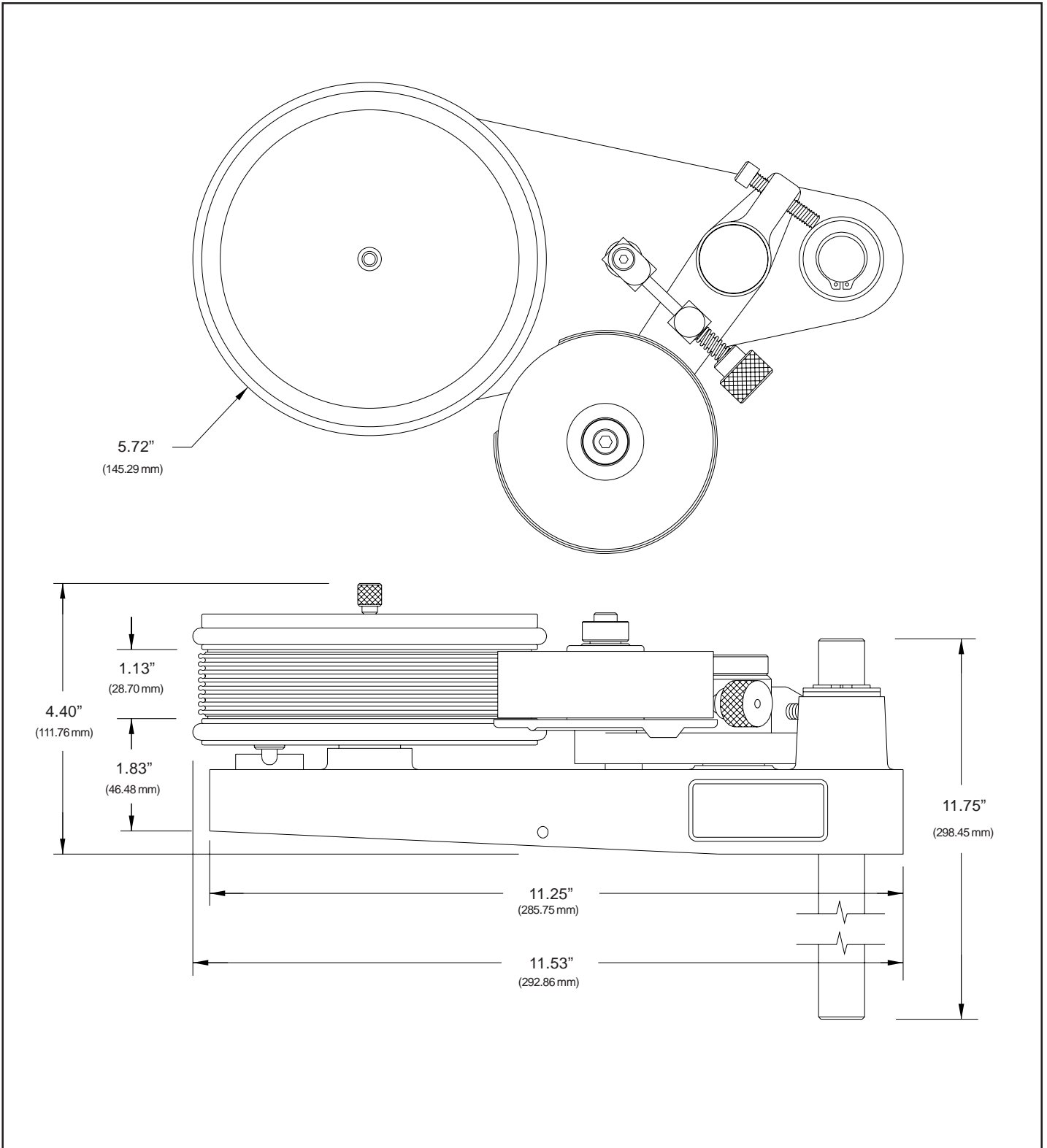

**NET WEIGHT:**

**8 LBS. - 14 OZ. (4.03 KG.)**

**MAXIMUM DIE SIZE - US STANDARD:**

**1" (7 RIBS) X 16-15/16" LENGTH**

**MAXIMUM DIE SIZE - METRIC CODERS ONLY:**

**25.4 MM (7 RIBS) X 430.2 MM LENGTH**

**PRINT DRUM CIRCUMFERENCE:**

**APPROXIMATELY 18" (457 MM) MEASURED AT DIE FACE**

# ABSORBENT CASE CODER PRINTER SPECIFICATIONS

## CA-218 SERIES

Model Shown: CA-218

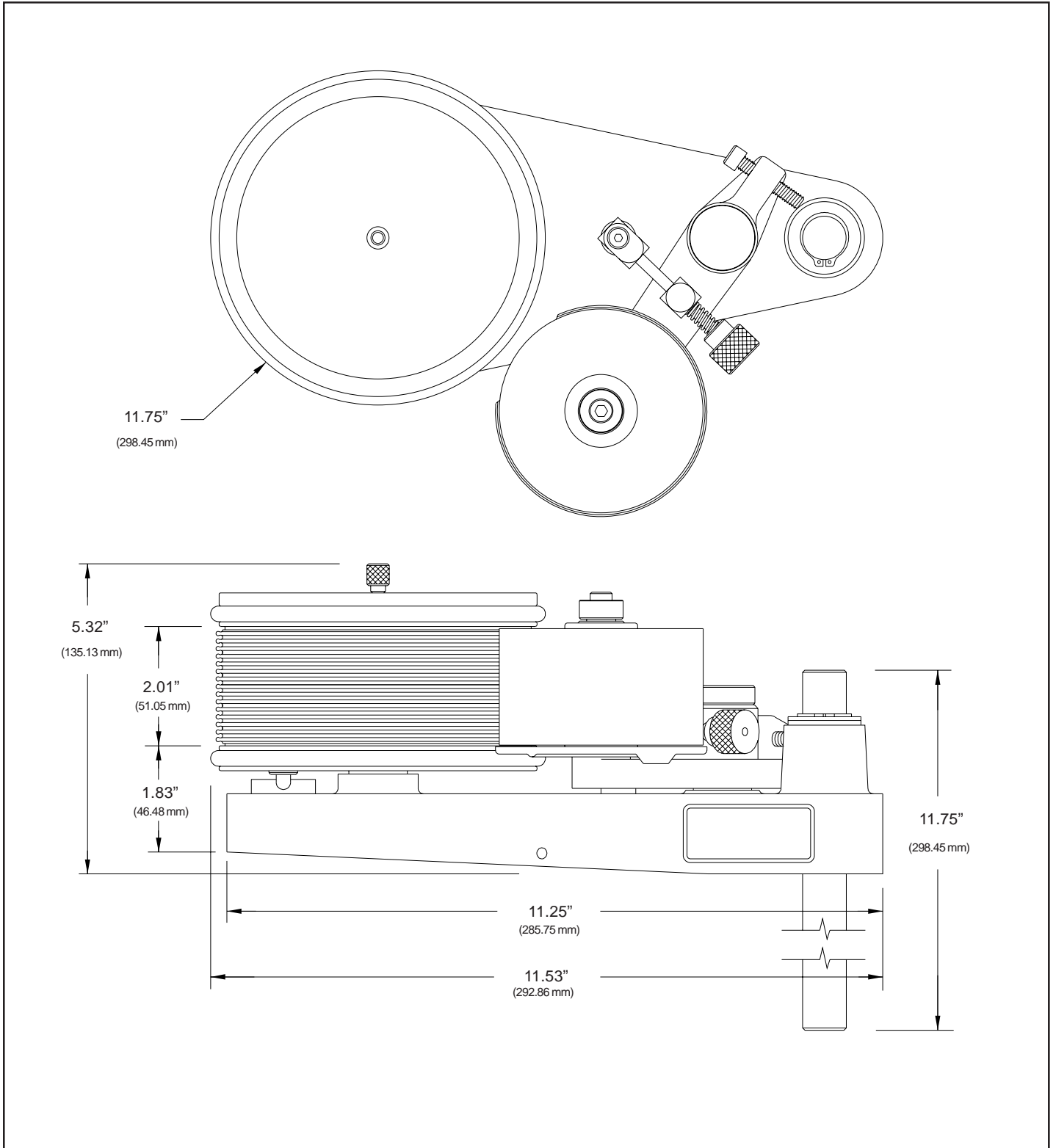

**NET WEIGHT:**  
**MAXIMUM DIE SIZE - US STANDARD:**  
**MAXIMUM DIE SIZE - METRIC CODERS ONLY:**  
**PRINT DRUM CIRCUMFERENCE:**

**9 LBS. - 7 OZ. (4.28 KG.)**  
**1-15/16" (14 RIBS) X 16-15/16" LENGTH**  
**49.2 MM (13 RIBS) X 430.2 MM LENGTH**  
**APPROXIMATELY 18" (457 MM) MEASURED AT DIE FACE**

# ABSORBENT CASE CODER PRINTER SPECIFICATIONS

## CA-318 SERIES

Model Shown: CA-318

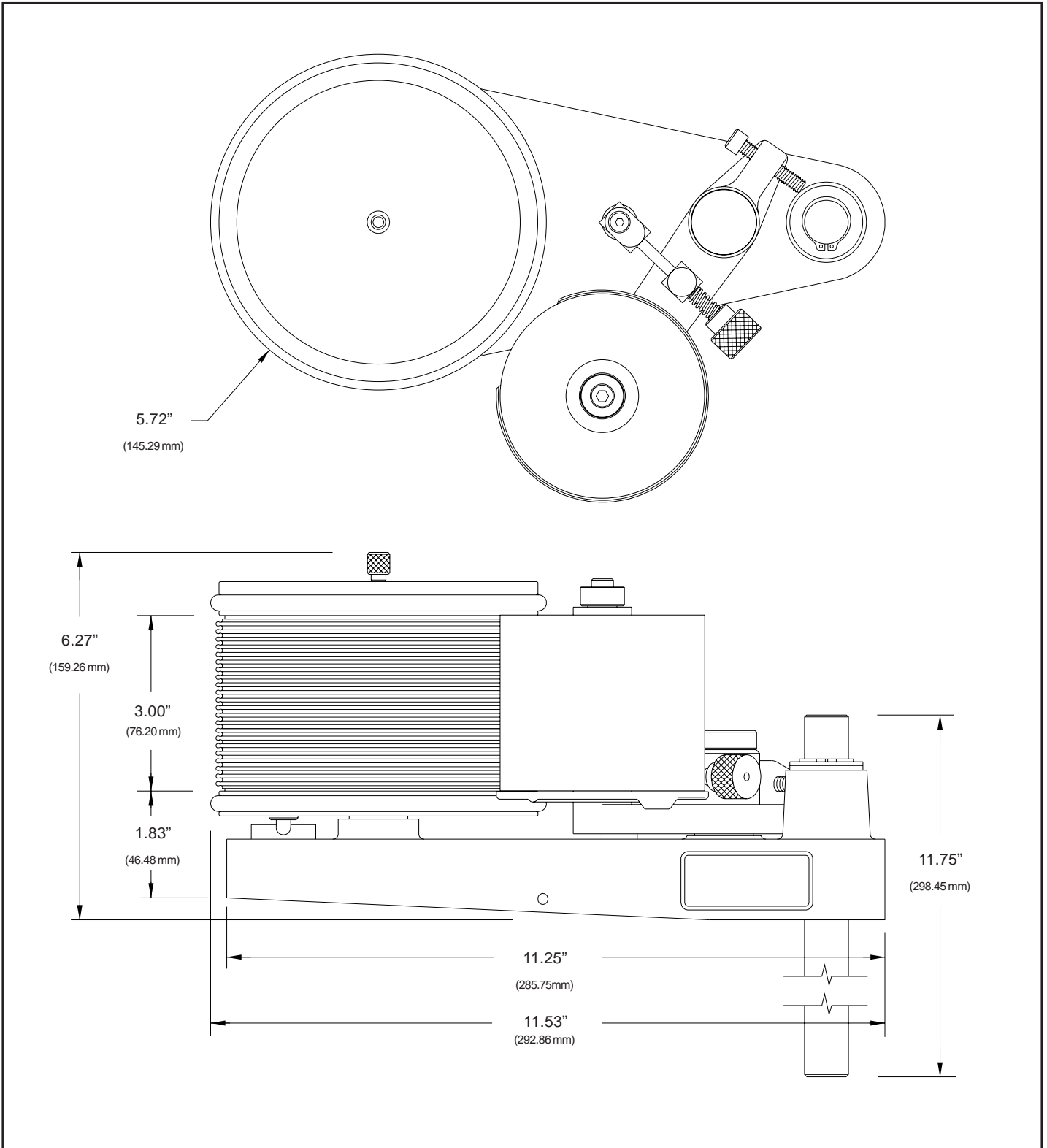

**NET WEIGHT:**

**10 LBS. - 5 OZ. (4.68 KG.)**

**MAXIMUM DIE SIZE - US STANDARD:**

**2-15/16" (21 RIBS) X 16-15/16" LENGTH**

**MAXIMUM DIE SIZE - METRIC CODERS ONLY:**

**74.6 MM (20 RIBS) X 430.2 MM LENGTH**

**PRINT DRUM CIRCUMFERENCE:**

**APPROXIMATELY 18" (457 MM) MEASURED AT DIE FACE**

**ABSORBENT CASE CODER PRINTER SPECIFICATIONS**  
**CA-418 SERIES**

Model Shown: CA-418

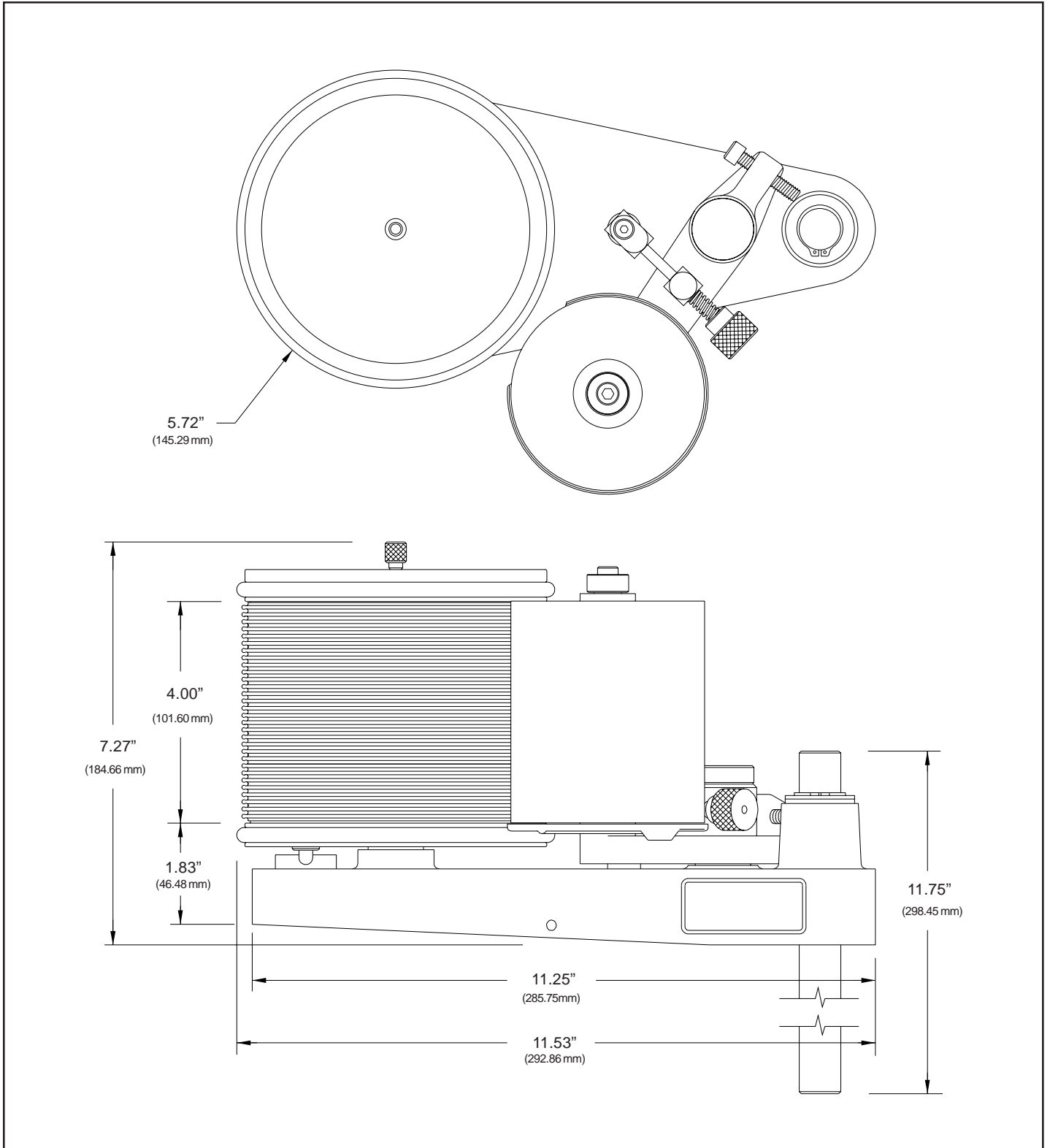

**NET WEIGHT:**  
**MAXIMUM DIE SIZE - US STANDARD:**  
**MAXIMUM DIE SIZE - METRIC CODERS ONLY:**  
**PRINT DRUM CIRCUMFERENCE:**

**10 LBS. - 15 OZ. (4.96 KG.)**  
**3-15/16" (29 RIBS) X 16-15/16" LENGTH**  
**100 MM (27 RIBS) X 430.2 MM LENGTH**  
**APPROXIMATELY 18" (457 MM) MEASURED AT DIE FACE**

---

---

# SPECIFICATIONS

---

---

## RESET AND CONTINUOUS MODELS

JMD Case Coders are available in both reset and continuous models.

Reset coders feature a print drum reset mechanism which provides print registration capabilities when carton printing (Figure 1). As the trailing edge of a carton passes the coder, the print drum is automatically rotated back to the same starting or "home" position. There must be adequate space between cartons at any given line speed for this mechanism to work properly. Printing with an reset coder will allow the imprint on each carton to be registered in the same position relative to the leading edge of the carton.

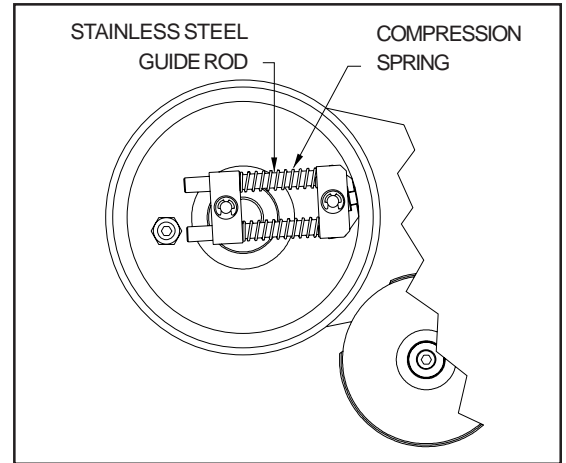

FIGURE 1

Continuous coders provide random print registration capabilities. These coders have print drums which simply rotate on bearings and repeat the print at an interval equal to the circumference of the print drum. If repeat intervals shorter than the print drum circumference are required, duplicate sets of dies can be installed on the print drum. Continuous coders are generally used for web printing applications where the print drum stays in contact with the web at all times.

## MOUNTING CONFIGURATION

The mounting configuration of a coder is determined by how the machine is designed to be mounted in relation to the product and its movement. All references to mounting configuration are made as though you are viewing the production line with the product moving away from you. JMD Case Coders are available from the factory in both righthand and lefthand mounting configurations. These can be installed in both top and side mount orientations as shown in Figures 2 and 3. Righthand or lefthand mounting configuration can be specified when ordering, however, the Case coder can be easily field converted.

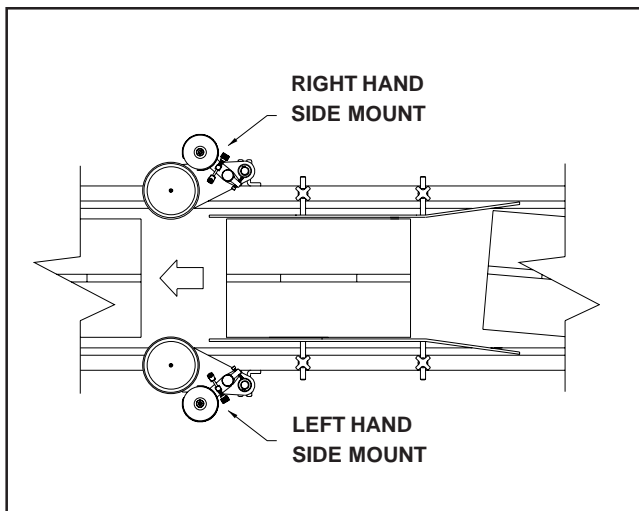

FIGURE 2

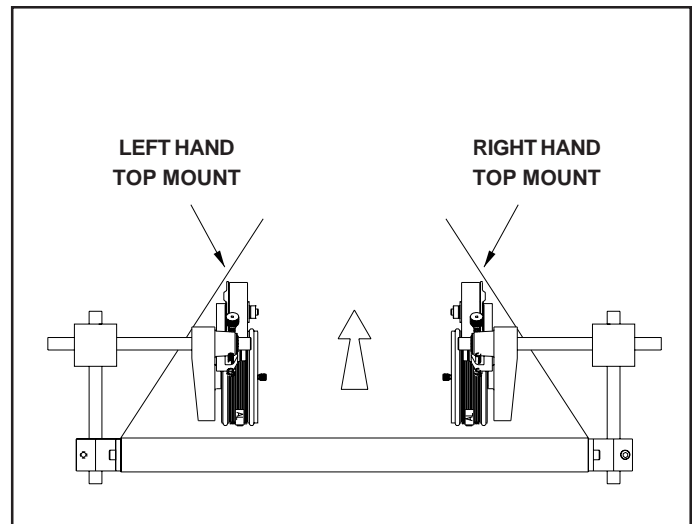

FIGURE 3

---

---

## **SPECIFICATIONS**

---

---

### **RIBtype® PRINTING DIES**

JMD Case Coders are designed to use RIBtype® printing dies which have a molded rib backing. The ribs on the back of the die snap into mating ribs in the Drum Cover on the print drum as shown in Figure 4.

The standard printing dies are available in sets with many sizes and character styles. The sets are a combination of individual alphabetic and numeric characters or in sets containing numeric characters only. These character sets or “sorts” can be used to make up text messages and code numbers as necessary.

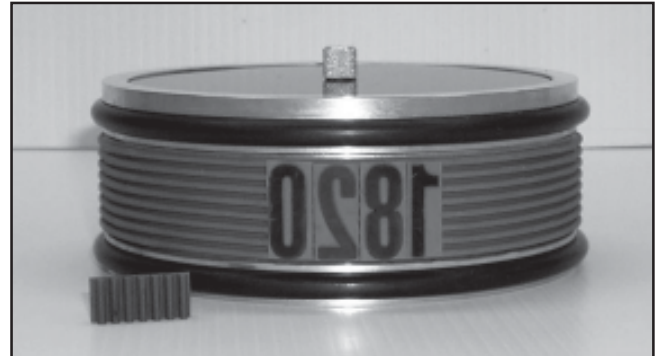

FIGURE 4

Printing dies are also available in “logo” form in which a complete text message, company logo or trademark is photographically reproduced from black and white art work on a single piece of rib backed rubber. These “logo” dies are more dimensionally stable than individual characters when installed on the print drum so they generally produce better print quality and are much faster to change in the field. For details on ordering custom logo dies, please contact our Customer Service Department.

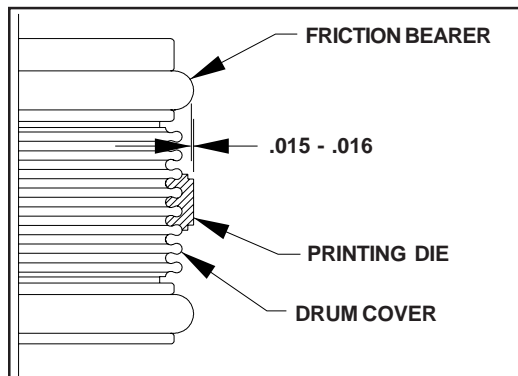

FIGURE 5

The dies are manufactured to precision thickness tolerances which are very critical to the performance of these coders. When installed, the face of the printing die should extend only .015" - .016" beyond the radius of the Friction Bearers as shown in Figure 5. Using dies that do not meet the design specifications will result in poor print quality and possible damage to the transfer roll.

Although there are several competitive rib backed die systems available, it is very important to note that they are not all made to the same rib spacing or thickness specifications and are not interchangeable.

### **CODER MODELS DESIGNED FOR METRIC RIBtype® PRINTING DIES**

JMD also offers Metric RIBtype® Die Systems for use in countries where metric character sizes are the standard. The Metric dies are thicker and the rib spacing differs slightly from the standard printing dies therefore the two versions are not compatible. To accommodate the differences, the print drums for Metric dies are machined to a slightly different diameter from the U.S. versions. The model numbers on Metric coders will have a “-T” suffix and have a distinct pink color.

---

---

# SPECIFICATIONS

---

---

## INK ROLLS

JMD offers three ink roll options for the Conveyor Line Printers each with unique characteristics which will help determine the suitability for a specific printing application. The coders are designed to accommodate all three types of ink rolls without modification. A detailed review of your printing requirements will determine the best choice of ink rolls for your particular application. All of these rolls are **re-inkable** for maximum economy.

### **MICROCELL INK ROLLS**

Microcell ink rolls are the most durable rolls available on the market today. This material is an extremely tough, hard density urethane foam which will last up to a year or more under normal conditions. Unless otherwise specified, Microcell Rolls are supplied with all new Conveyor Line Printers and are recommended for use with **JMD #1150 Ink** or equivalent for printing on corrugated cartons and other **absorbent** surface materials.



FIGURE 6

### **XF NEOPRENE INK ROLLS**

JMD's XF Neoprene Ink Rolls are made from an extra firm density neoprene material. While not quite as durable as Microcell, the extremely fine cell structure of these rolls provides exceptionally good print quality particularly when using small character printing dies. Due to their greater ability to compensate for slight die thickness variations, these rolls are also recommended to correct print quality problems when multiple lines of text are required.

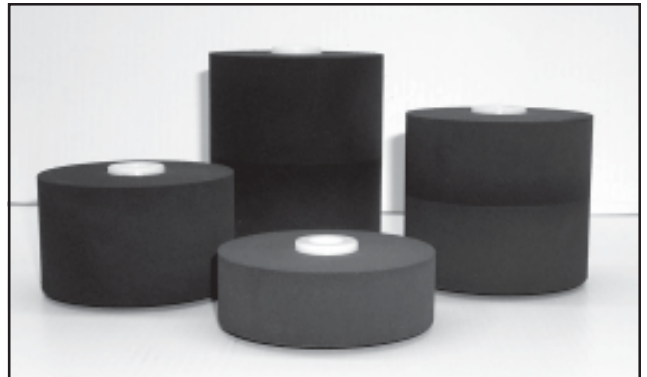

FIGURE 7

### **NEOPRENE INK ROLLS**

JMD's Neoprene ink rolls are made from a soft density neoprene material. Because this material has a larger cell structure, it is designed for use with heavily **pigmented inks** for carton printing on **absorbent** materials.

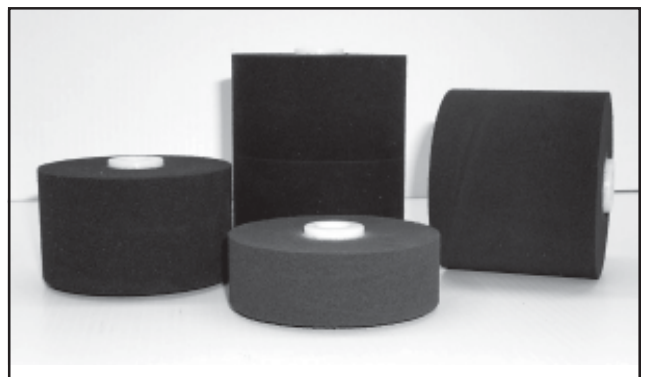

FIGURE 8

---

---

## QUICK START

---

---

### **PRE-INKING MICROCELL ROLLS ONLY!**

***If you ordered a pre-inked roll, skip to page 12.***

*(See inking instructions on page 27 for XF Neoprene and Neoprene ink rolls)*

JMD Case Coder Printers are shipped from the factory fully assembled and, unless otherwise specified, include a **dry Microcell Ink Roll**. The ink roll must be manually pre-inked prior to use. Dry ink rolls **cannot** be properly inked using only the 4 Oz. Reservoir Ink Cartridges. The initial inking of any dry roll is a critical process. The following instructions will guide you through the inking and installation process and have your coder ready to use in a few minutes.

***Inks will stain clothing, furniture, carpeting and your hands. Rubber gloves should be worn during the following procedures.***

- 1- Remove the ink roll from the plastic bag. Fill a clean dry container with enough ink to allow the ink roll to fully submerge.

Microcell Ink Rolls are designed for use with JMD #1150 Ink for marking on absorbent surfaces. The ink rolls must be pre-inked manually prior to installation on the coder. The 4 Oz. Reservoir Ink Cartridges cannot be used to ink any dry roller.



FIGURE 9

- 2- Carefully place the ink roll into the ink. Do not force the roll to submerge. The top surface of the roll must remain dry during this process.

The roll should be allowed to float, undisturbed, in the container of ink. Leaving the top surface of the roll dry allows air to escape as the ink is absorbed from the bottom. Forcing the roll under the surface of the ink will prevent the roll from absorbing ink properly.

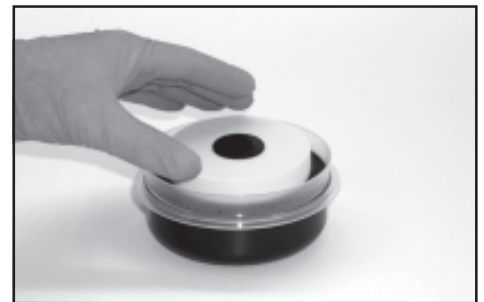

FIGURE 10

- 3- As the roll absorbs ink it will begin to sink into the container. When the top surface becomes fully saturated the roll has absorbed as much ink as possible. Using a screwdriver, remove the roll from the container.

This process normally takes 20-25 minutes for a 1-1/8" face roll, longer for the larger rolls. Proper inking of a dry roll is critical to ensure good performance of the roll. When fully saturated, a 1-1/8" face roll will hold approximately 4 ounces (118 ml.) of ink, a 2" face roll will hold approximately 8 ounces (236 ml) of ink, a 3" face roll will hold approximately 12 ounces (354 ml) of ink and a 4" face roll will hold approximately 16 ounces (473 ml) of ink.



FIGURE 11

- 4- To remove excess ink from the roller, place a round shaft through the core (a screw driver will work nicely) and roll the inked roller across a clean piece of paper or cardboard.

After inking, the roll will be oversaturated with ink. A small volume of ink must be removed or the roller will drip.

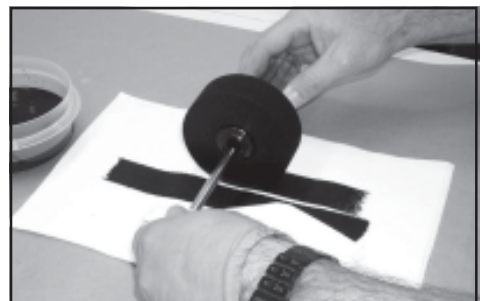

FIGURE 12

---

---

## QUICK START

---

---

### INSTALLING THE PRE-INKED ROLL

*Inks will stain clothing, furniture, carpeting and your hands. Rubber gloves should be worn during the following procedures.*

- 1- If you received a pre-inked ink roll with your coder, the roll will be slightly oversaturated with ink. To remove excess ink from the roller, place a round shaft through the core (a screw driver will work nicely) and roll the inked roller across a clean piece of paper or cardboard.

**A small volume of ink must be removed or the roller will drip.**

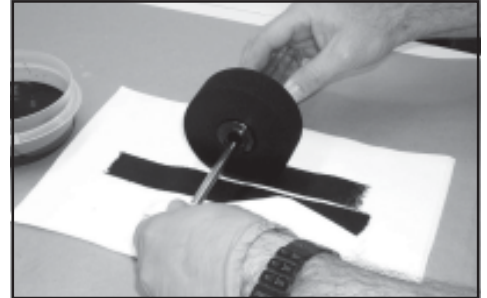

FIGURE 13

- 2- To install the ink roll, first remove the 1/4-20 Mounting Screw and the Axle Cap from the Ink Roll Axle.

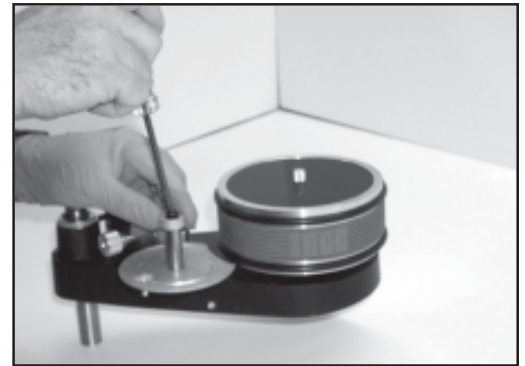

FIGURE 14

- 3- Place the ink roll on the Axle. Do not allow the ink roll to contact the Print Drum Friction Bearer Rings during installation. If necessary, pull the Pivot Arm away from the Print Drum to prevent contact.



FIGURE 15

- 4- Replace Axle Cap with recessed side up and reinstall Mounting Screw.



FIGURE 16

---

---

## QUICK START

---

---

### INSTALLING THE PRINTING DIES

To make die installation easier, moisten a sponge with water containing a **small** amount of liquid dish detergent. Lightly moisten the back of the printing die and then immediately press the die into the drum cover.

**Note:** Do not apply too much liquid or the dies will slip during printing.

Install the Printing Die on the Print Drum by aligning the ribbed backing on the die with the mating drum cover on the Print Drum. Press firmly until they are completely engaged.

Individual character codes or text messages are installed in a mirror image of normal written text. In other words install in a right to left direction as shown. When printed, codes or text installed in this orientation will print in normal left to right order.



FIGURE 17

### OPTIONAL TYPE BLOCKING KIT

When using small individual characters with only a two or three rib backing, an optional Type Blocking Kit (Stock No. UR-BK) should be used to support the leading and trailing ends of the type as shown.

Characters which have only a 2 or 3 rib backing do not have the stability of the larger character sizes when snapped into the drum cover. Adding the rib backed type blocks on either side of the code will provide added stability and prevent the characters from shifting during printing. The Type Blocks are not as thick as the Type and will not pick up ink from the Ink Roll.



FIGURE 18

---

---

## QUICK START

---

---

### ADJUSTING THE INK ROLL / DIE FACE CONTACT PRESSURE

The pressure the ink roll exerts on the face of the printing dies should be just enough to rotate the ink roll and completely ink the face of the dies as they pass during printing. Excessive contact pressure will cause smudging of the impression, premature failure of the ink roll, and restriction of the print drum rotation.

- 1- With the dies installed on the print drum, rotate the print drum to a position where the printing dies will contact the ink roll. Then using a 3/16" hex wrench, adjust the Pivot Arm Position Adjusting Screw as necessary to move the ink roll into contact with the die face.

The ink roll should never be positioned so close that it contacts the Drum Covering on the Print Drum.



FIGURE 19

- 2- Rotate the Print Drum and observe the die face/ink roll contact. The dies should contact the ink roll with adequate pressure to rotate the ink roll and transfer ink only to the face of the printing dies.

Excessive contact pressure will cause ink to well to the surface of the ink roll and result in poor print quality. With a fully saturated ink roll, excessive contact pressure can also cause ink to drip from the coder. Adjust the Pivot Arm Position Adjusting Screw as necessary to ensure the die faces are completely inked.

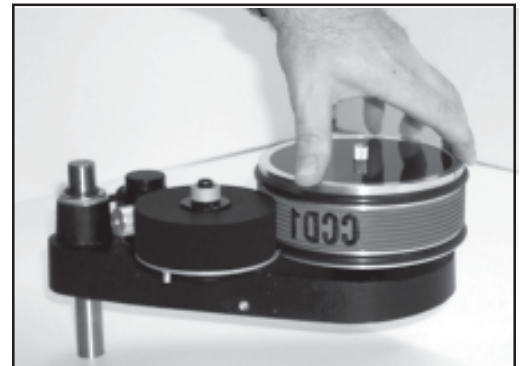

FIGURE 20

- 3- The Pivot Arm Assembly is designed to automatically compensate for slight variations in die thickness which result from normal wear. The Pivot Arm Compression spring enables the ink roll to deflect slightly from the set position when die variations are encountered. The knurled Pivot Arm Adjusting Knob is used to adjust the spring tension and it should be set to apply just enough tension to ensure complete inking of the die faces.

Do not over tighten the Adjusting Knob or you will not allow the machine to automatically compensate for slight die height variations.



FIGURE 21

---

---

## QUICK START

---

---

### **USING THE OPTIONAL RESERVOIR ROLL COVERS AND 4 OZ. RESERVOIR INK CARTRIDGES**

Optional Reservoir Roll Covers are available for both side mount and top mount coder installations. When installed, these covers enable the use of the patented 4 Oz. Reservoir Ink Cartridges which re-ink the ink roll automatically during the printing operation. This system can be installed in the field in a few minutes and can be used with both Microcell and XF Neoprene Ink Rolls.

Unlike gravity fed systems which will allow ink to flow continuously, JMD's Reservoir Ink Cartridges feed ink only during the print cycle. Ink feed stops automatically during inactive periods.

**SIDE MOUNT RESERVOIR ROLL COVERS** are available in sizes to fit all models of the Case Coder Printers and mount with a standard Axle Cap Screw. Models for the Case-100 and Case-200 series coders have a single port for a 4 Oz. Reservoir Ink Cartridge. Models for the Case-300 and Case-400 series coders have dual ports for the installation of one or two 4 Oz. Cartridges to accommodate the larger print capacities.

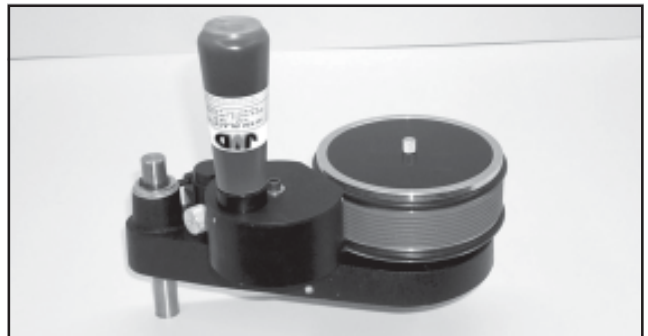

FIGURE 22

**TOP MOUNT RESERVOIR ROLL COVERS** are also available in sizes to fit all models of the Case Coder Printers and mount with a standard Axle Cap Screw. Models for the Case-100 and Case-200 series coders have a single port for a 4 Oz. Reservoir Ink Cartridge. Models for the Case-300 and Case-400 series coders have dual ports for the installation of two 4 Oz. Cartridges to accommodate the larger print capacities.



FIGURE 23

**Note:** The 4 oz. Reservoir Ink Cartridge is designed to be installed only when the ink roll becomes depleted of ink. Allow the coder to run without the cartridge until the print quality indicates a need for additional ink. **Do not install a Reservoir Cartridge when the Ink Roll is fully saturated or over saturation and dripping will result.**

To install the Reservoir Roll Cover, remove the Ink Roll Mounting Screw and Axle Cap. Place the Reservoir Roll Cover over the ink roll with the open side facing the Print Drum. Install and tighten the Mounting Screw. When the ink roll requires more ink, remove the white cap from the Reservoir Cartridge and thread the bottle into the port until it stops. After installing the cartridge, the print quality should return to normal within a few seconds on top mount machines, slightly longer on side mount machines.

When the reservoir ink cartridge is empty, do not immediately install a new cartridge. Remove the empty cartridge and wait until the print quality begins to show signs of needing ink before installing a new one. This will prevent the ink roll from becoming over saturated.

---

---

# CARTON PRINTING

---

---

## CARTON ALIGNMENT

The selection of an appropriate place for installation on your conveyor line or other packaging equipment is a very important consideration in the performance of your coder. The most important factor to consider is carton alignment. To ensure accurate and consistent print registration and to prevent damage to your coder, the cartons must be accurately guided through the printing station by guide rails (Figure 24). If your conveyor is not equipped with guide rails, they must be installed before proceeding with coder installation.

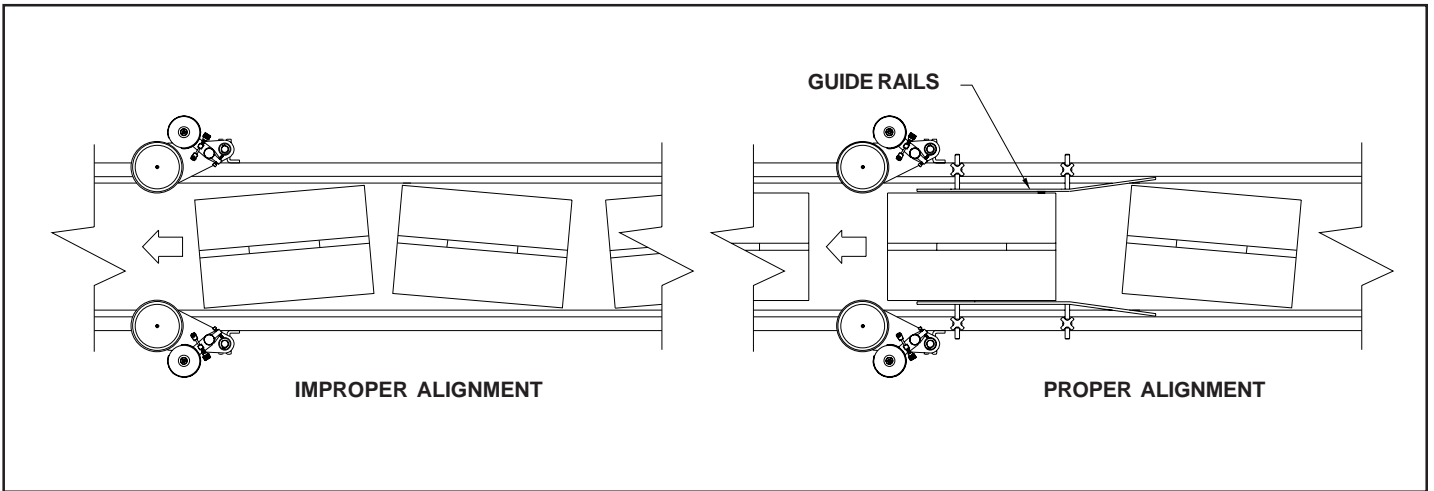

FIGURE 24

Before tightening the mounting screws, check the alignment of the coder and ensure that the top of the print drum is parallel to the conveyor belt as shown in Figure 25. Also ensure that both Friction Bearer Rings on the print drum contact the side of the carton with equal pressure as shown in Figure 26. If necessary, thin shims can be placed behind the top or bottom edge of the Mounting Bracket to achieve proper friction bearer contact.

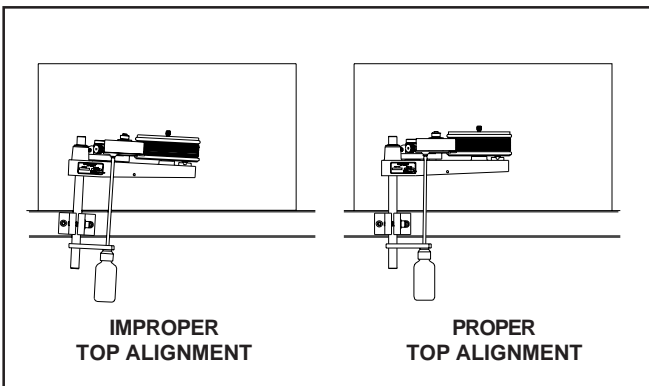

FIGURE 25

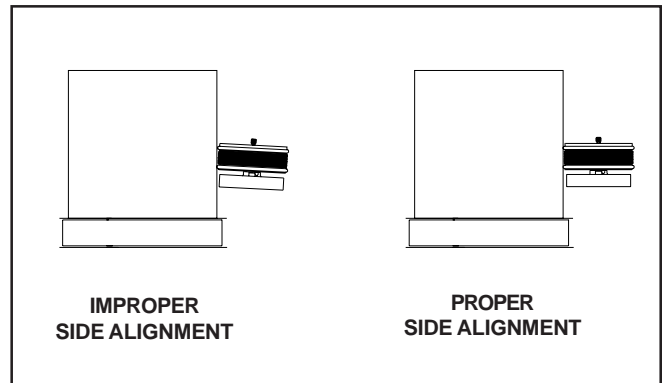

FIGURE 26

---

---

# CARTON PRINTING

---

---

## SETTING THE SPRING TENSION MECHANISM

In most applications, installation of the printer can be accomplished by attaching the mounting bracket to the side rails of the powered conveyor using two 3/8" machine bolts. The printers should be mounted as close as possible to the end of the guide rails to insure that proper carton alignment is maintained at the printing station.

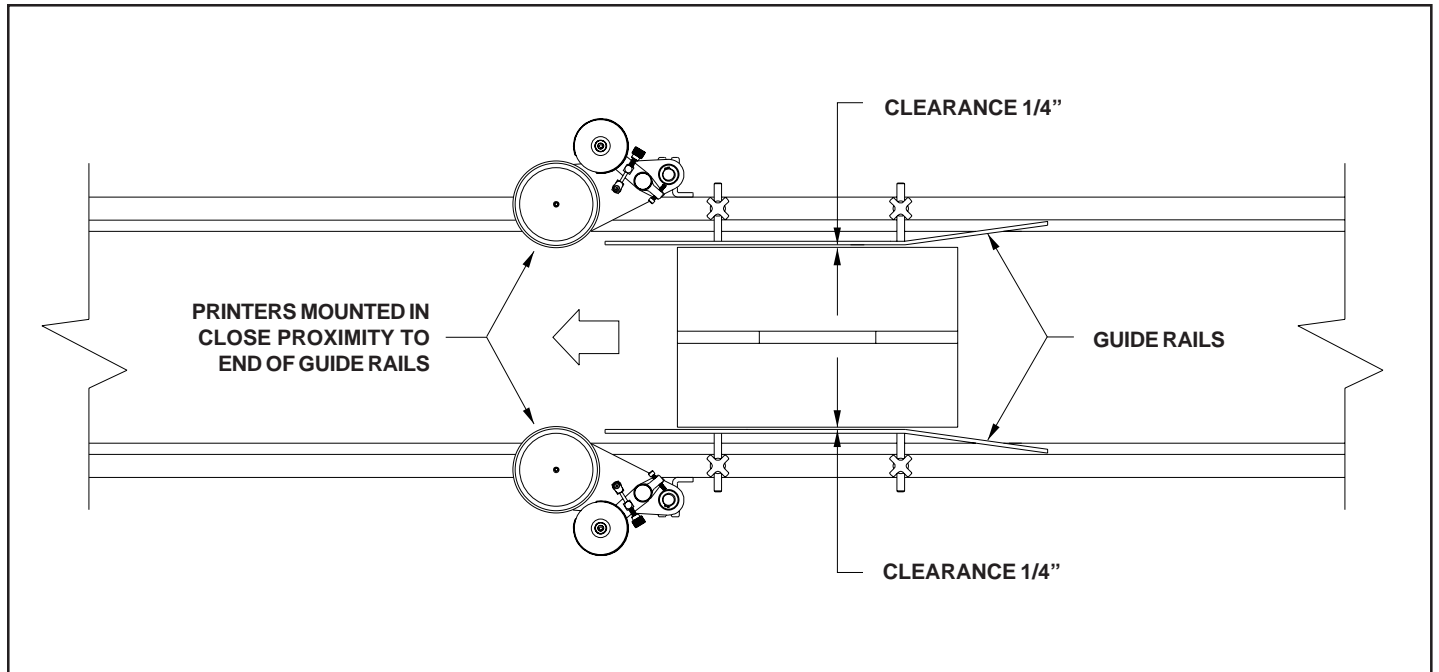

FIGURE 27

JMD Case coders are designed so the frame of the machine will pivot on the mounting column. This allows the print drum to deflect, or swing, on contact with the leading edge of the carton a maximum of 3/4". It is recommended that cartons be aligned between guide rails with no more than 1/4" clearance on each side as shown in Figure 27. This should allow ample clearance for cartons and protect your printer from damage.

Loosen the Mounting Column Clamping Screw (Figure 28) and position the printer to the required height for printing. Swing the printer into position so the print drum will lightly contact the side of the cartons as they emerge from between the guide rails and tighten the Clamping Screw.

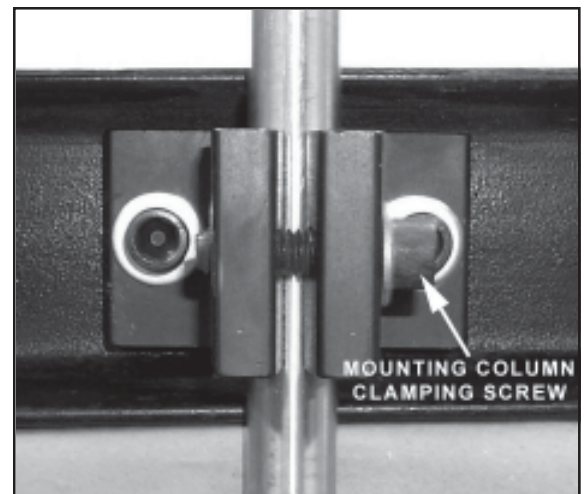

FIGURE 28

---

---

## **CARTON PRINTING**

---

---

Check the print drum contact with the cartons while the conveyor is under power and adjust the print drum position to obtain approximately 1/4" - 3/8" deflection (Figure 29).

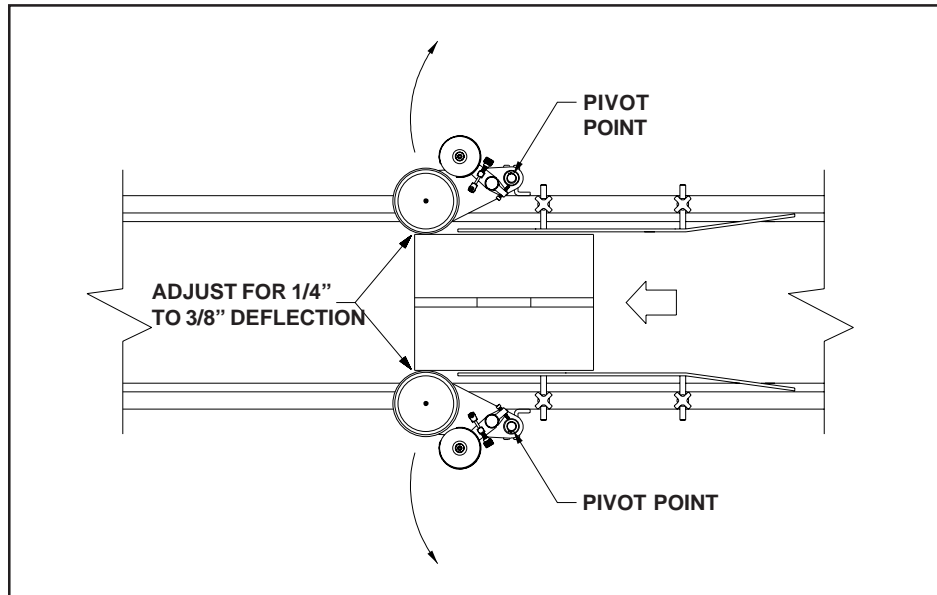

FIGURE 29

### ***DIE POSITIONING FOR RESET APPLICATIONS***

Continuous models of the Case Coder do not offer print registration capabilities, therefore mounting the printing dies at a specific location on the print drum is not important. On reset machines, the position of the die on the print drum will determine the location of the print on the carton.

Figure 30 illustrates the best die position for carton printing. Note that the leading edge of the printing die should be positioned, rotationally, upstream of the ink roll. When the leading edge of the carton contacts the print drum, the drum begins to rotate in a clockwise direction. The die travels a short distance and then contacts the ink roll where ink is applied to the die face. When the die contacts the carton, the mark is applied. The print drum will continue to rotate until the trailing edge of the carton passes the coder, then the print drum will automatically return to the same starting position.

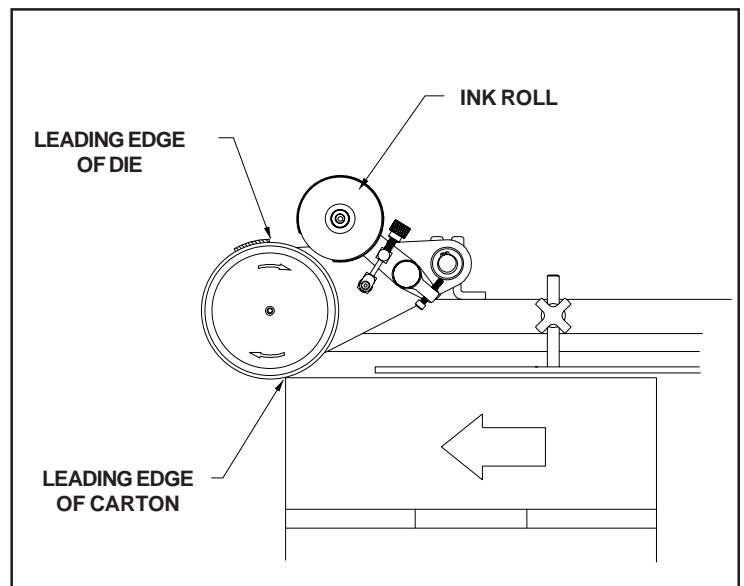

FIGURE 30

---

---

## **MAINTENANCE**

---

---

### **CLEANING THE CODER / CLEANING THE PRINTING DIES**

If proper installation procedures are followed, the maintenance of your new coder will be limited to periodic cleaning to remove dust and any ink residue which may accumulate during operation. The frequency of this maintenance procedure is dependent upon the environmental conditions and proper inking of the coder. To remove ink contamination from the surface of the coder, moisten a soft cloth with a light solution of detergent and water and wipe away any contamination. During printing, the dies will tend to pick up both airborne dust and any dust or dirt on the surface of the material being printed. After some period of use, the accumulation of contaminants on the dies will cause degradation of the print quality. When this happens, the dies should be cleaned or replaced. Cleaning the dies is a very easy process and, excluding excessive wear to the die face, will restore the print quality of the die to like new condition.

JMD #1150 Ink is a glycol base ink which can be easily cleaned from the dies without the use of solvents. The easiest method of cleaning dies is to scrub the die face with a toothbrush using liquid dish detergent and water. Since the ink residue will stain, it is highly recommended that you wear a pair of rubber gloves, safety glasses and an apron to protect your clothing. (Naturally, the toothbrush will never be suitable for oral hygiene use after this process.)

- 1- Place the contaminated die on top of several layers of paper towels to absorb the excess liquid. Pour just enough soapy water on the face of the printing die to cover the die face.

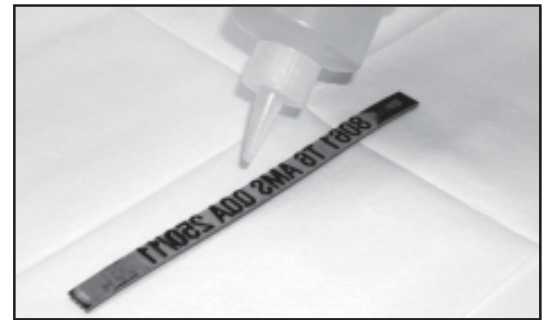

FIGURE 31

- 2- Using the toothbrush, carefully scrub the face of the die to remove the contamination and old ink as shown. Add more soapy water as necessary and repeat the process until the die is clean. Rinse the dies in clean water.

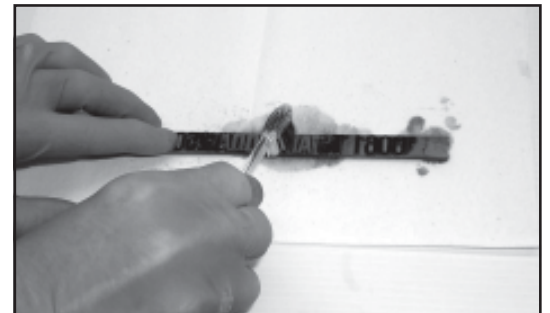

FIGURE 32

- 3- Blot the surface of the die with a clean paper towel to dry and reinstall the clean dies on the coder.

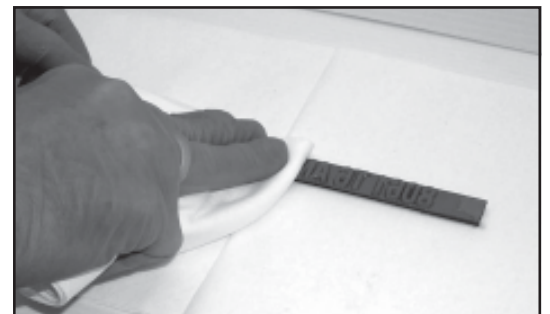

FIGURE 33

---

---

## MAINTENANCE

---

---

### **PRE-INKING NEOPRENE & XF NEOPRENE FOAM ROLLS**

Ink Rolls made from Neoprene materials are inked using a different procedure than inking the Microcell Ink Rolls.

***Inks will stain clothing, furniture, carpeting and your hands. Rubber gloves should be worn during the following procedures.***

- 1- Remove the dry roll from the plastic bag. Pour ink into a clean container large enough to accommodate the size of the ink roll.

For a 1-1/8" face roll pour approximately 4 ozs. of ink into the container, for a 2" face - 8 ozs., 3" face - 12 ozs. and 4" face - 16 ozs. The ink rolls must be pre-inked manually prior to installation on the coder. The 4 Oz. Reservoir Ink Cartridges **cannot** be used to ink a dry roller.

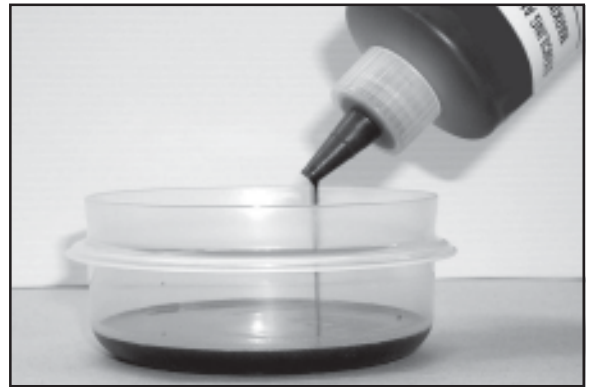

FIGURE 34

- 2- Place the roll on it's side into the container. Using your finger tips, press down firmly on the side of the roll. Continue to press down on the roll while rotating it in the container. Flip the roll over in the container and repeat the process until the all of the ink is absorbed.

As you press down on the ink roll you are forcing the air out of the roll which allows the ink to be absorbed.



FIGURE 35

- 3- Using a screwdriver, remove the roll from the container. Roll the ink roll across a clean piece of paper or cardboard to remove the excess ink.

It is important to the performance of the coder that the ink roll is fully saturated with ink but not dripping wet. When fully saturated, a 1-1/8" face roll will hold approximately 4 ounces (118 ml.) of ink, a 2" face roll will hold approximately 7 ounces (209 ml.) of ink, a 3" face roll will hold approximately 10 ounces (313 ml.) of ink and a 4" face roll will hold approximately 14 ounces (418 ml.) of ink.

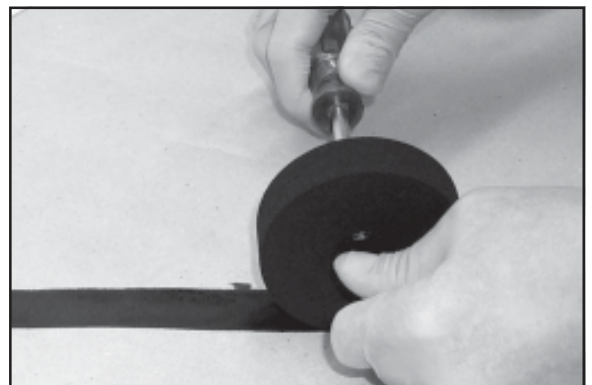

FIGURE 36

---

---

# MOUNTING CONFIGURATION CONVERSION

---

---

## LEFTHAND/RIGHTHAND FIELD CONVERSION

Mounting configuration conversion involves the “mirror image” reversal of the pivot arm assembly that holds the ink roll and the tension arm assembly which provides the printing pressure. Reset printers require the additional reversal of the index ramp and repositioning of the index ring.

JMD Case Coders are assembled at the factory for either righthand or lefthand mounting. If field conversion is required, the following steps will guide you through the conversion process.

### PIVOT ARM ASSEMBLY CONVERSION

- 1- Remove the ink roll from the coder.
- 2- Loosen the Knurled Nut to relieve spring tension on the Pivot Arm.
- 3- Remove the Pivot Screw and lift the spring assembly off of the coder.
- 4- Remove the Pivot Arm Cap and lift the Pivot Arm assembly off its axle.
- 5- Replace Pivot Arm on the axle with the ink recovery tray on the opposite side of the print drum and replace the Pivot Arm Cap.
- 6- Rotate the Ink Recovery Tray so the Drain Nozzle will be facing away from the coder.
- 7- Remove the Position Adjusting Screw and reinstall in the reverse position.
- 8- Replace the spring assembly and Pivot Screw.
- 9- Readjust Knurled Nut to apply adequate spring pressure.

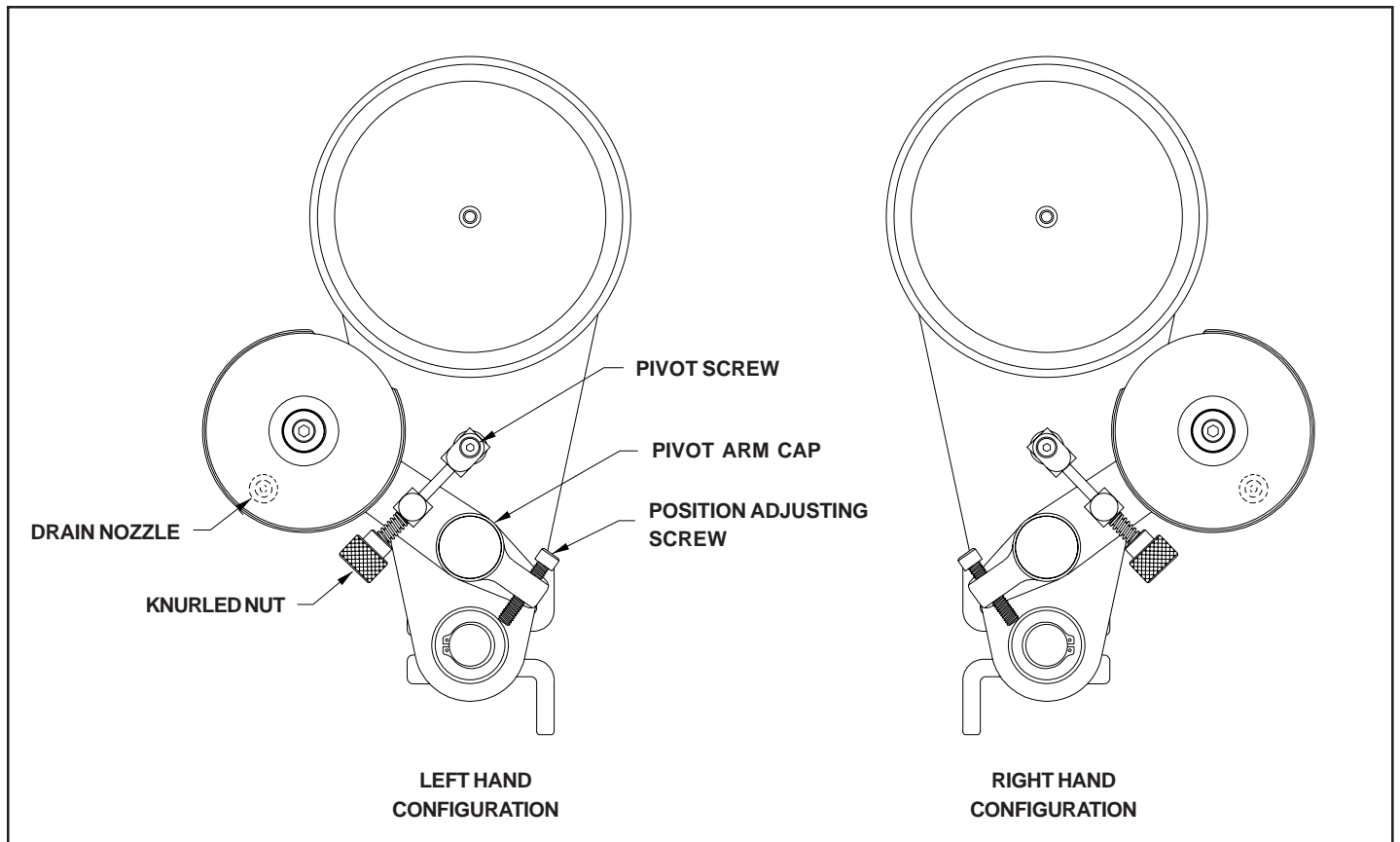

FIGURE 37

# MOUNTING CONFIGURATION CONVERSION

## TENSION ARM ASSEMBLY CONVERSION

- 1- Loosen the Lock Nut and screw the Adjusting Bolt in to relieve the spring pressure (Figure 38).
- 2- Remove the spring by lifting the end off the Locating Button.
- 3- Remove the Adjusting Bolt and replace it on the opposite side of the Tension Arm.
- 4- Remove the Spring Cup and replace it on the opposite side of the Tension Arm.
- 5- Replace the Spring by inserting one end into the Spring Cup and lifting the other end over the Locating Button.
- 6- Readjust the position of the Adjusting Bolt to center the Tension Arm between the sides of the coder base plate. Snug the Lock Nut against the Tension Arm to prevent movement from conveyor vibration.

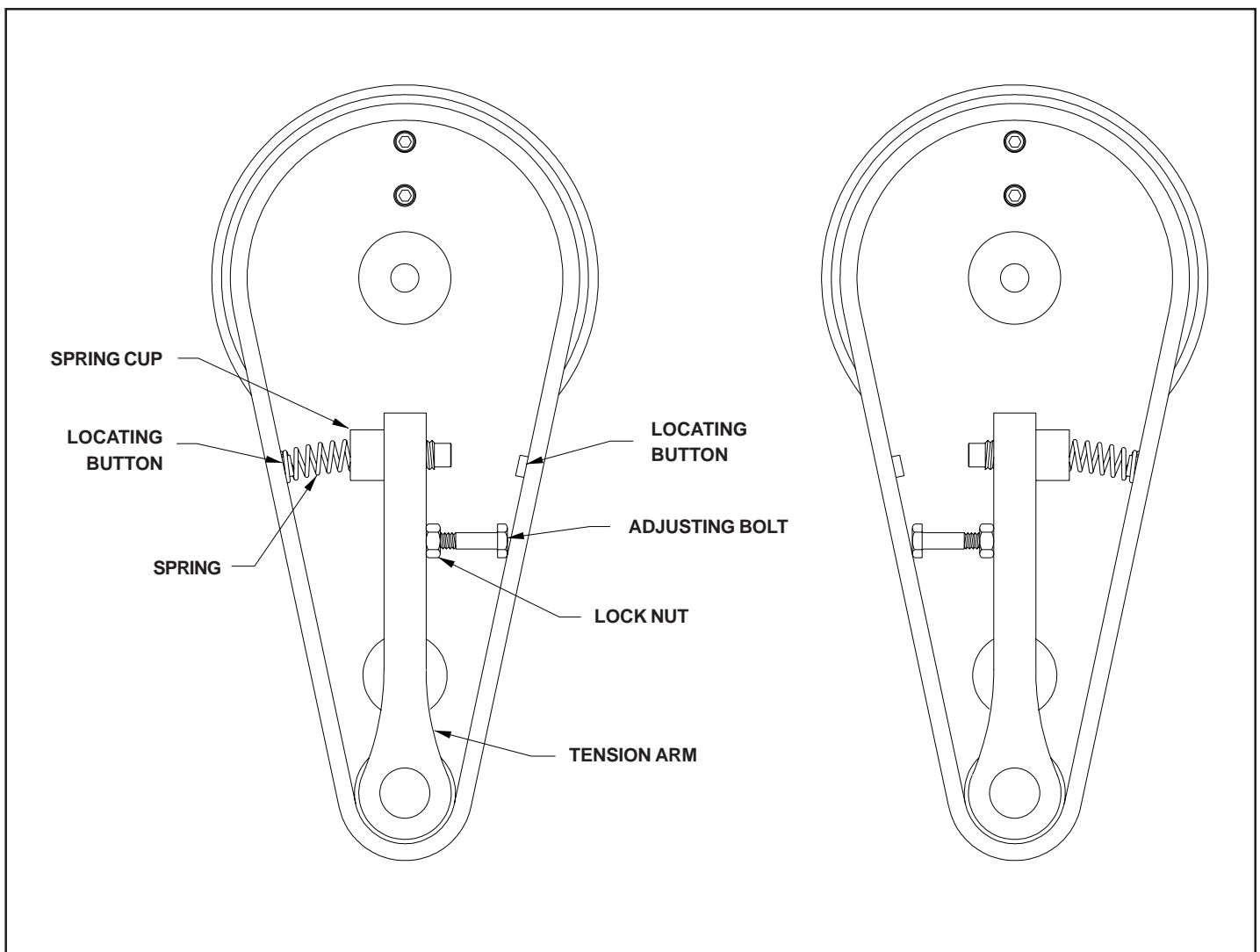

FIGURE 38

---

---

## ***MOUNTING CONFIGURATION CONVERSION***

---

---

### ***PRINT DRUM INDEX MECHANISM CONVERSION***

1- Using a 5/64" hex wrench, loosen the Nylon Tip Set Screw located in the top rim of the Print Drum as shown in Figure 39.



FIGURE 39

2- Remove the Print Drum Dust Cover.



FIGURE 40

3- To relieve the spring tension on the index mechanism, rotate the Print Drum approximately 3/4 turn. The Index Compression Springs will now be in the fully extended (relaxed) position as shown.



FIGURE 41

4- Using a 5/32" hex wrench, remove the two Index Ramp Mounting Screws which are located on the under side of the Coder Baseplate. The Index Ramp will be reinstalled in the opposite orientation to allow the Print Drum to turn in the reverse direction.



FIGURE 42

## MOUNTING CONFIGURATION CONVERSION

- 5- Using a 1/8" hex wrench, loosen the Brass Tipped Set Screw located in the side of the Index Ring until the Index Ring rotates freely. The Brass Tip Set Screw must be loosened at least 2 full turns to prevent damage to the threads.

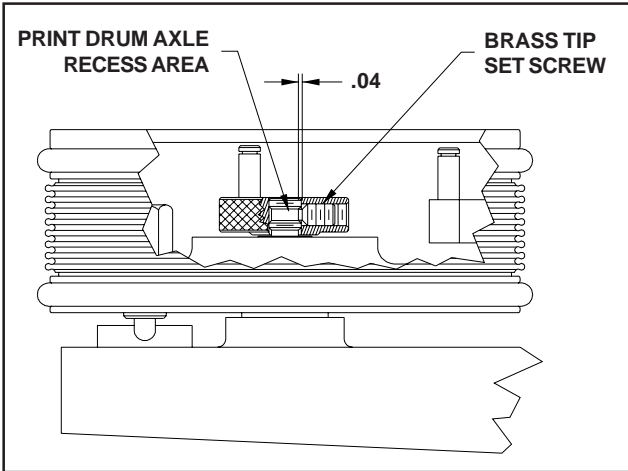

FIGURE 44



FIGURE 43

**Important Note:** The Print Drum Axle is machined with thread relief as shown in Figure 44 so the tip of the set screw will not damage the threads.

- 6- Rotate the Index Ring in a clockwise direction until it stops turning. Next, turn the Index Ring in the counter-clockwise direction as necessary until the Brass Tip Set Screw is pointing directly at the Ink Roller Axle as shown in Figure 45.

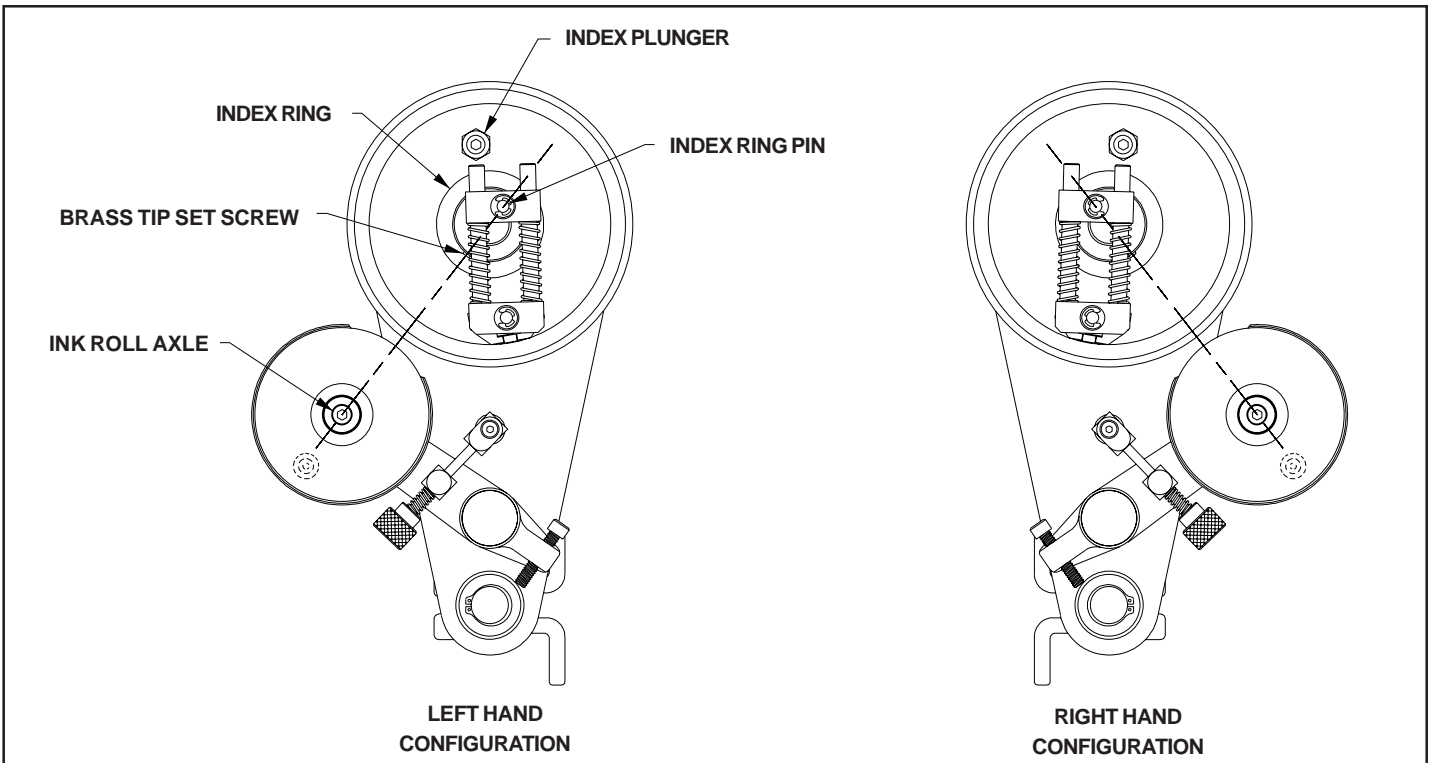

FIGURE 45

- 7- Re-tighten the Brass Tipped Set Screw to lock the Index Ring in position. This screw must be tight to prevent the Index Ring from rotating under spring tension.

---

---

## ***MOUNTING CONFIGURATION CONVERSION***

---

---

8- Reinstall the Index Ramp in the proper orientation for your mounting configuration as shown below.

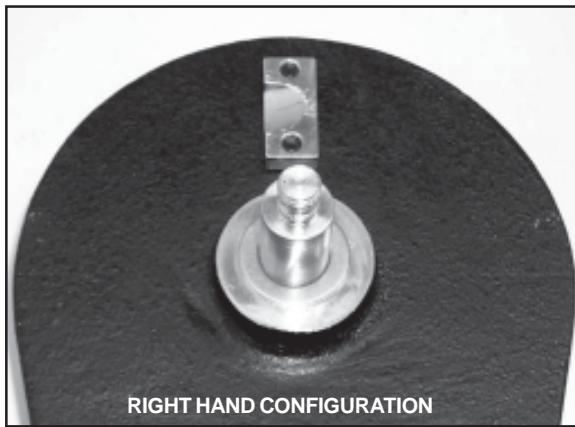

FIGURE 46

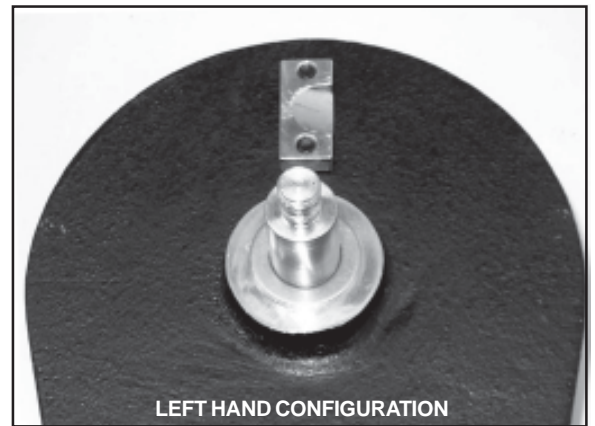

FIGURE 47

### ***REPLACING PRINT DRUM INDEX SPRINGS***

1- To replace Print Drum Index Springs, rotate the Print Drum approximately 3/4 turn to relieve spring tension as shown in Figure 41, Page 23.

2- Using a small screwdriver, remove the two Snap Rings on the Index Spring Assembly.



FIGURE 48

3- Remove the Index Spring Assembly by lifting it straight up off the pivot pins.



FIGURE 49

---

---

## ***MOUNTING CONFIGURATION CONVERSION***

---

---

- 4- Holding onto the Index Assembly Block “A”, pull the Index Assembly Block “C” off the guide shafts (Figure 50).  
Remove the Drum Index Springs (Figure 51)

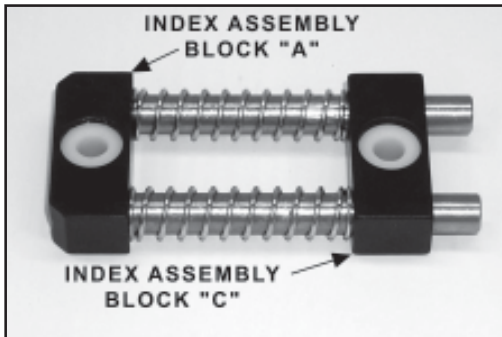

FIGURE 50

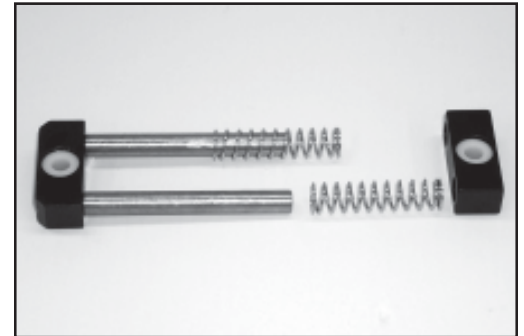

FIGURE 51

- 5- Install new Index Springs over the stainless steel guide shafts and replace Index Block “C”.
- 6- Reinstall the Index Spring Assembly in the Print Drum with the white bushings facing the open end of the Print Drum.
- 7- Reinstall the two Snap Rings.

### ***REMOVING AND REPLACING INDEX BLOCK “B”***

- 1- To remove Index Block “B” from the Print Drum, roll down the Drum Cover directly behind the Index Block to expose the Index Assembly Mounting Screw. Using a screw driver, turn the Mounting Screw in a clockwise direction until the Index Block becomes loose and can be removed.



FIGURE 52

---

---

## MOUNTING CONFIGURATION CONVERSION

---

---

2- Lift Index Block “B” straight up to remove.

The head of the Index Assembly Mounting Screw engages the T-Slot in Index Block “B”. This mounting design facilitates height adjustment of the Index Block during reassembly.



FIGURE 53

**Before replacing Index Block “B”, ensure that the Index Ring is properly adjusted as explained in Steps 5 - 7 on Page 24.**

3- When replacing Index Block “B” it is very important to align the top surface of the Index Block with the top surface of the Index Ring as shown.

The easiest way to accomplish this is to hold a flat block of metal or wood across the top of the Index Ring. While holding the block in place, raise Index Block “B” up to contact the bottom of the alignment block.



FIGURE 54

4- While holding Index Block “B” in this position, tighten the Index Assembly Mounting Screw by turning it counter-clockwise until tight.



FIGURE 55

# CASE CODER ASSEMBLY

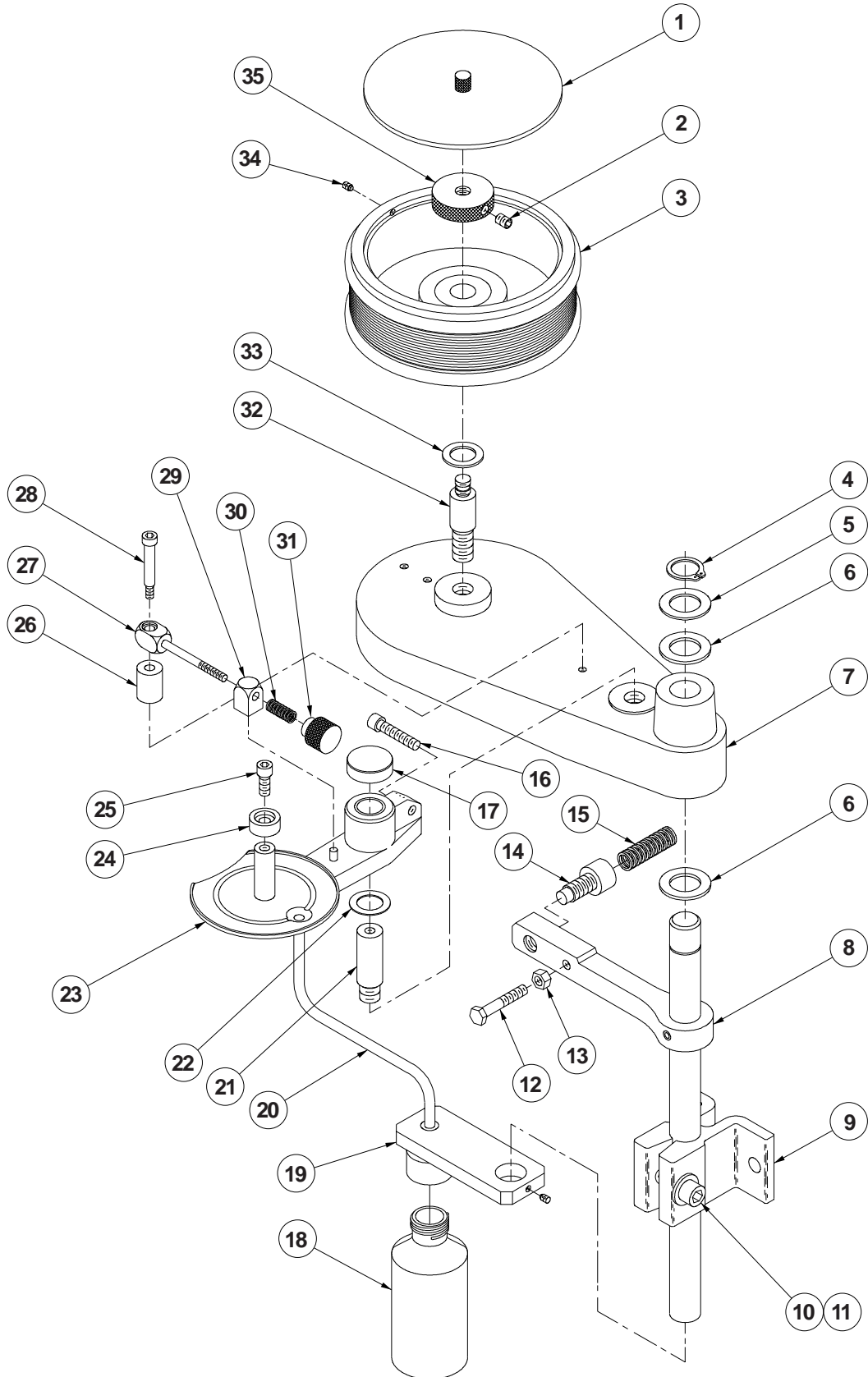

## CASE CODER ASSEMBLY PARTS LIST

KEY NO.	PART NUMBER	QTY. REQD.	DESCRIPTION
1	CM-13	1	DUST COVER W/KNURLED KNOB
2	CF-04	1	SET SCREW, 1/4-20 X 3/8 BTS
3	CA-118NI-PDA	1	CA-118 CONTINUOUS PRINT DRUM ASSEMBLY
	CA-118-PDA		CA-118 RESET PRINT DRUM ASSEMBLY
	CA-218NI-PDA		CA-218 CONTINUOUS PRINT DRUM ASSEMBLY
	CA-218-PDA		CA-218 RESET PRINT DRUM ASSEMBLY
	CA-318NI-PDA		CA-318 CONTINUOUS PRINT DRUM ASSEMBLY
	CA-318-PDA		CA-318 RESET PRINT DRUM ASSEMBLY
	CA-418NI-PDA		CA-418 CONTINUOUS PRINT DRUM ASSEMBLY
	CA-418-PDA		CA-418 RESET PRINT DRUM ASSEMBLY
	CA-118NI-PDA-T		CA-118 CONTINUOUS PRINT DRUM ASSEMBLY - METRIC
	CA-118-PDA-T		CA-118 RESET PRINT DRUM ASSEMBLY - METRIC
	CA-218NI-PDA-T		CA-218 CONTINUOUS PRINT DRUM ASSEMBLY - METRIC
	CA-218-PDA-T		CA-218 RESET PRINT DRUM ASSEMBLY - METRIC
	CA-318NI-PDA-T		CA-318 CONTINUOUS PRINT DRUM ASSEMBLY - METRIC
	CA-318-PDA-T		CA-318 RESET PRINT DRUM ASSEMBLY - METRIC
CA-418NI-PDA-T	CA-418 CONTINUOUS PRINT DRUM ASSEMBLY - METRIC		
CA-418-PDA-T	CA-418 RESET PRINT DRUM ASSEMBLY - METRIC		
4	CF-13	1	SNAP RING FOR 3/4" SHAFT
5	CW-01	1	3/4" STEEL FLAT WASHER
6	CW-05	2	3/4" NYLON FLAT WASHER
7	CC-01	1	BASE PLATE ASSEMBLY
8	Case-MCA	1	MOUNTING COLUMN ASSEMBLY
9	CM-17	1	MOUNTING COLUMN BRACKET
10	CW-02	1	3/8" STEEL FLAT WASHER
11	CF-09	1	SCREW, 3/8-16 X 1-1/2" SHC
12	CF-10	1	HEX BOLT, 1/4-20 X 1-1/2
13	CF-11	1	HEX NUT, 1/4-20
14	CM-25	1	TENSION ARM SPRING ADJUSTING CUP ASSEMBLY
15	CS-06	1	TENSION ARM COMPRESSION SPRING
16	CF-02	1	SCREW, 1/4-20 X 1-1/4" SHC
17	CM-16	1	PIVOT ARM CAP
18	CM-12	1	4 OZ. RECOVERY BOTTLE
19	Case-RB	1	RECOVERY BOTTLE BRACKET ASSEMBLY
20	CT-01	1	DRAIN TUBE
21	CA-03	1	PIVOT ARM AXLE

## **CASE CODER ASSEMBLY PARTS LIST**

KEY NO.	PART NUMBER	QTY. REQD.	DESCRIPTION
22	CW-04	1	BRASS WASHER
23	Case-PA1	1	CA-118 PIVOT ARM ASSEMBLY
	Case-PA2		CA-218 PIVOT ARM ASSEMBLY
	Case-PA3		CA-318 PIVOT ARM ASSEMBLY
	Case-PA4		CA-418 PIVOT ARM ASSEMBLY
24	CM-01	1	INK ROLL AXLE CAP
25	MC-02	1	SCREW, 1/4-20 X 5/8" SHC
26	CM-26	1	PIVOT ARM SPRING ASSEMBLY POST
27	Case-PAB	1	PIVOT ARM BLOCK "B" ASSEMBLY
28	CF-26	1	PIVOT ARM SHOULDER SCREW
29	CM-27	1	PIVOT ARM BLOCK "A"
30	CS-05	1	PIVOT ARM COMPRESSION SPRING
31	CM-30	1	PIVOT ARM ADJUSTING KNOB
32	CA-06	1	CA-118 PRINT DRUM AXLE
	CA-02	1	CA-218 PRINT DRUM AXLE
	CA-01	1	CA-318 & 400 PRINT DRUM AXLE
33	CW-03	1	PRINT DRUM BRASS WASHER
34	CF-05	2	SET SCREW, 8-32 X 3/16" S.S. NTS
35	CM-04	1	KNURLED RETAINING RING

## **CASE DRY INK ROLLS FOR 100, 200, 300 & 400 SERIES CODERS**

Case-SERIES	PART NUMBER	DESCRIPTION
CA-118 SERIES	1001-118MC-C	1-1/8" MICROCELL INK ROLL - DRY
	1001-118XF-C	1-1/8" XF NEOPRENE INK ROLL - DRY
	1001-118NF-C	1-1/8" NEOPRENE INK ROLL - DRY
CA-218 SERIES	1002-218MC-C	2" MICROCELL INK ROLL - DRY
	1002-218XF-C	2" XF NEOPRENE INK ROLL - DRY
	1002-218NF-C	2" NEOPRENE INK ROLL - DRY
CA-318 SERIES	1003-318MC-C	3" MICROCELL INK ROLL - DRY
	1003-318XF-C	3" XF NEOPRENE INK ROLL - DRY
	1003-318NF-C	3" NEOPRENE INK ROLL - DRY
CA-418 SERIES	1004-418MC-C	4" MICROCELL INK ROLL - DRY
	1004-418XF-C	4" XF NEOPRENE INK ROLL - DRY
	1004-418NF-C	4" NEOPRENE INK ROLL - DRY

## CASE CODER PIVOT ARM ASSEMBLY

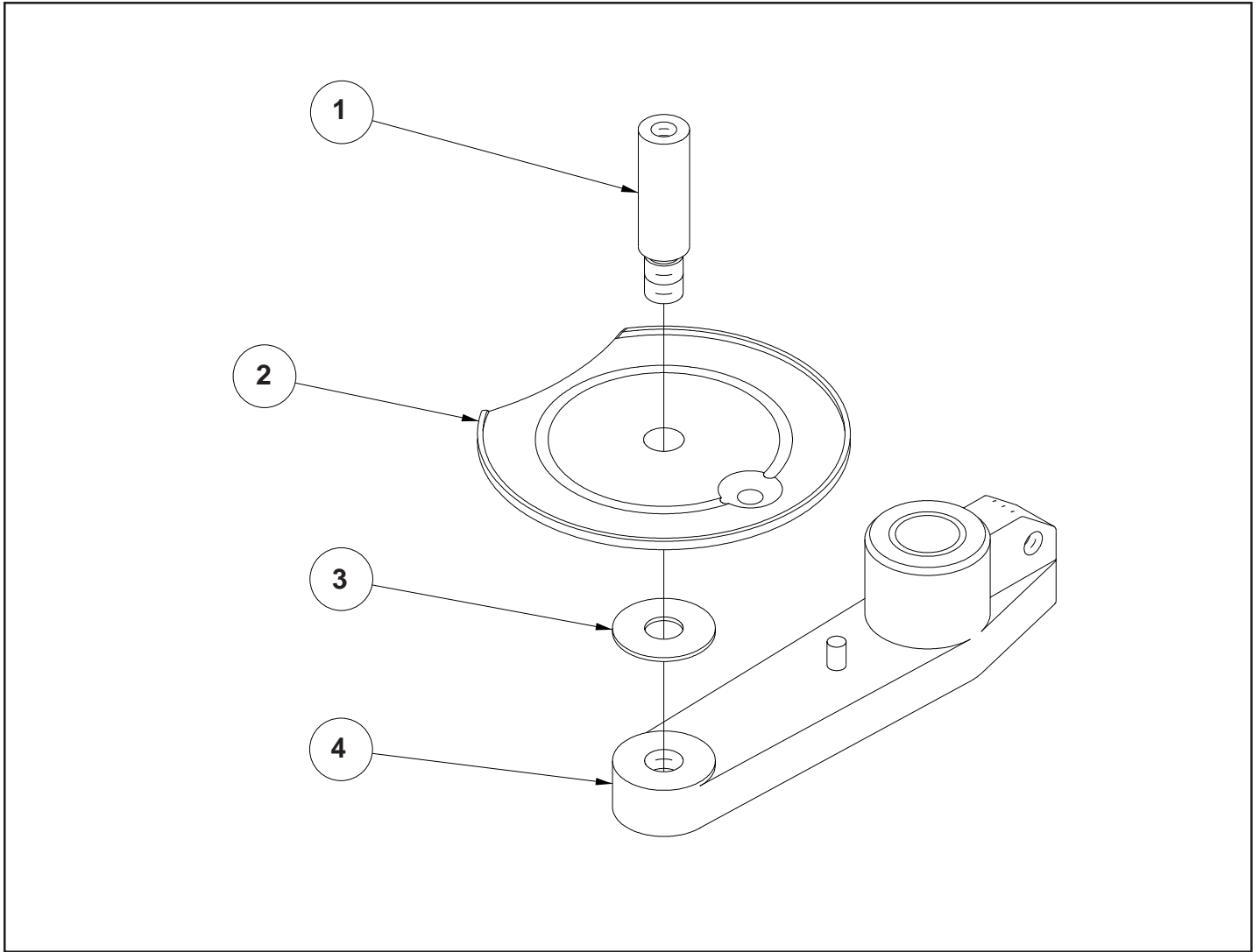

### CASE CODER PIVOT ARM ASSEMBLY PARTS LIST

KEY NO.	PART NUMBER	QTY. REQD.	DESCRIPTION
1	CA-07	1	CA-118 INK ROLL AXLE
	CA-05		CA-218 INK ROLL AXLE
	CA-08		CA-318 INK ROLL AXLE
	CA-04		CA-418 INK ROLL AXLE
2	Case-RT	1	RECOVERY TRAY ASSEMBLY
3	CW-06	1	RECOVERY TRAY DELRIN WASHER
4	Case-PA	1	PIVOT ARM SUB-ASSEMBLY

## CASE CODER PRINT DRUM ASSEMBLY

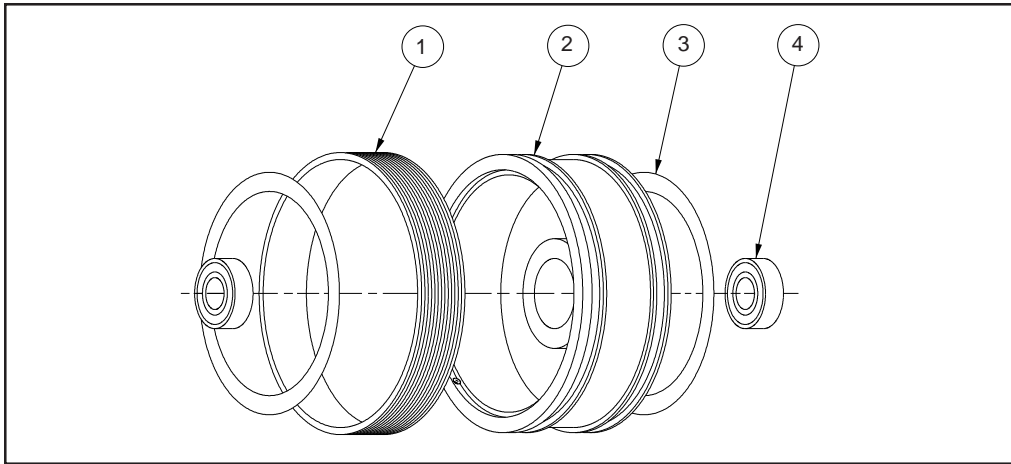

### CASE CODER PRINT DRUM COMPONENT PARTS LIST

KEY NO.	PART NUMBER	QTY. REQD.	DESCRIPTION
1	Case-BL1	1	Case-100-RIBtype® DRUM COVER
	Case-BL2		Case-200-RIBtype® DRUM COVER
	Case-BL3		Case-300-RIBtype® DRUM COVER
	Case-BL4		Case-400-RIBtype® DRUM COVER
	Case-BL1T		Case-100-RIBtype® DRUM COVER - METRIC
	Case-BL2T		Case-200-RIBtype® DRUM COVER - METRIC
	Case-BL3T		Case-300-RIBtype® DRUM COVER - METRIC
	Case-BL4T		Case-400-RIBtype® DRUM COVER - METRIC
2	Case-PD1	1	Case-100 CONTINOUS PRINT DRUM W/CB-04 PRINT DRUM BEARINGS
	Case-PD1I		Case-100 RESET PRINT DRUM W/CB-04 PRINT DRUM BEARINGS
	Case-PD2		Case-200 CONTINOUS PRINT DRUM W/CB-04 PRINT DRUM BEARINGS
	Case-PD2I		Case-200 RESET PRINT DRUM W/CB-04 PRINT DRUM BEARINGS
	Case-PD3		Case-300 CONTINOUS PRINT DRUM W/CB-04 PRINT DRUM BEARINGS
	Case-PD3I		Case-300 RESET PRINT DRUM W/CB-04 PRINT DRUM BEARINGS
	Case-PD4		Case-400 CONTINOUS PRINT DRUM W/CB-04 PRINT DRUM BEARINGS
	Case-PD4I		Case-400 RESET PRINT DRUM W/CB-04 PRINT DRUM BEARINGS
	Case-PD1T		Case-100 CONTINOUS PRINT DRUM W/CB-04 PRINT DRUM BEARINGS - METRIC
	Case-PD1IT		Case-100 RESET PRINT DRUM W/CB-04 PRINT DRUM BEARINGS - METRIC
	Case-PD2T		Case-200 CONTINOUS PRINT DRUM W/CB-04 PRINT DRUM BEARINGS - METRIC
	Case-PD2IT		Case-200 RESET PRINT DRUM W/CB-04 PRINT DRUM BEARINGS - METRIC
	Case-PD3T		Case-300 CONTINOUS PRINT DRUM W/CB-04 PRINT DRUM BEARINGS - METRIC
	Case-PD3IT		Case-300 RESET PRINT DRUM W/CB-04 PRINT DRUM BEARINGS - METRIC
	Case-PD4T		Case-400 CONTINOUS PRINT DRUM W/CB-04 PRINT DRUM BEARINGS - METRIC
	Case-PD4IT		Case-400 RESET PRINT DRUM W/CB-04 PRINT DRUM BEARINGS - METRIC
3	CO-02	2	BEARER RING
4	CB-04	2	PRINT DRUM BEARING

## CASE CODER RESET ASSEMBLY

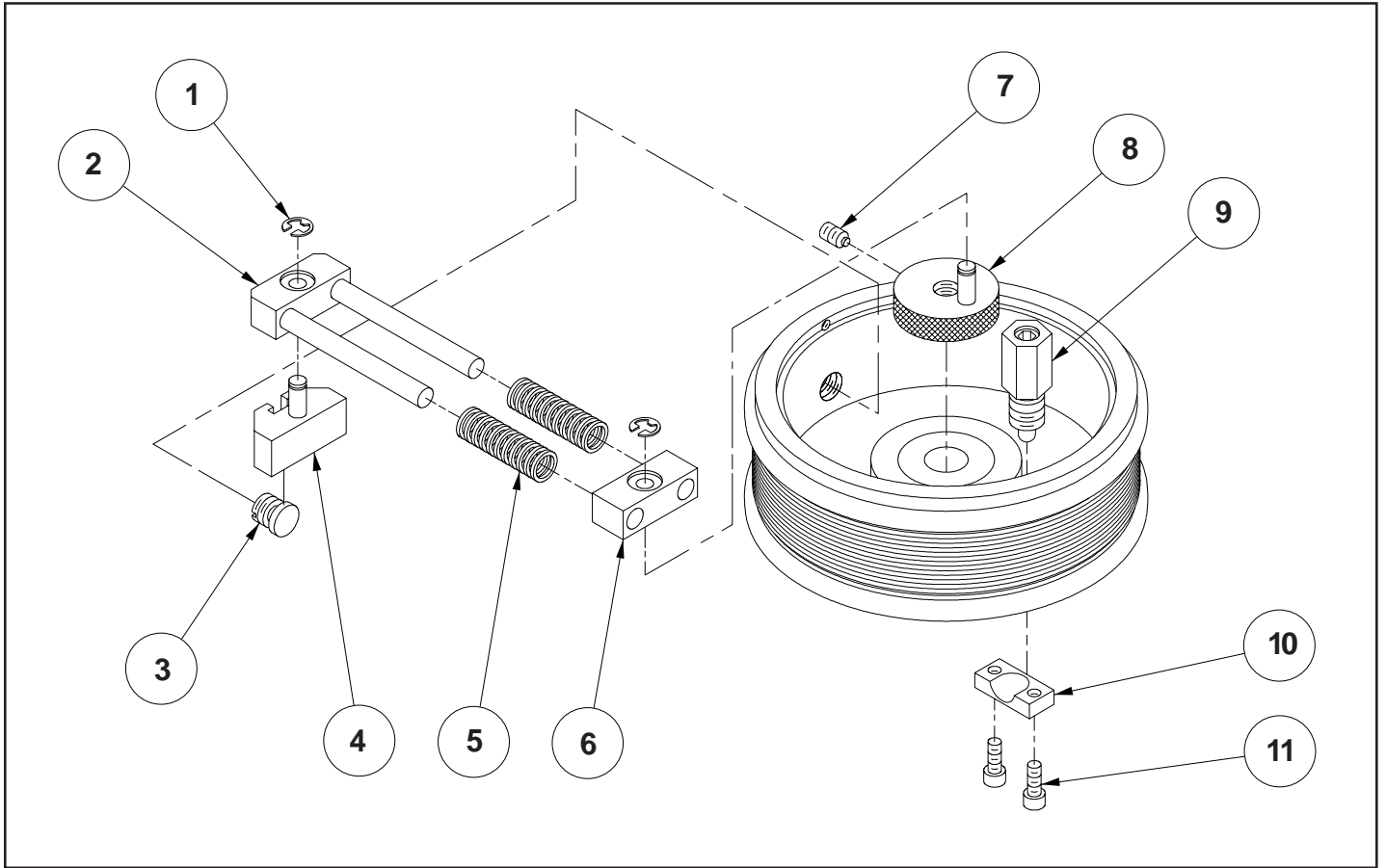

### CASE CODER RESET ASSEMBLY PARTS LIST

KEY NO.	PART NUMBER	QTY. REQD.	DESCRIPTION
1	CF-28	2	SNAP RING
2	Case-IA	1	INDEX ASSEMBLY BLOCK "A"
3	CF-27	1	INDEX ASSEMBLY MOUNTING SCREW
4	Case-IB	1	INDEX ASSEMBLY BLOCK "B"
5	CS-07	2	DRUM INDEX SPRING
6	Case-IC	1	INDEX ASSEMBLY BLOCK "C"
7	CF-04	1	1/4-20 BRASS TIP SET SCREW
8	Case-IR2	1	INDEX RING ASSEMBLY
9	Case-IP	1	INDEX PLUNGER ASSEMBLY
10	CM-34	1	INDEX RAMP
11	CF-29	2	SCREW, 10-32 X 1/2" SHC

