



## Technical Bulletin

### **MM-12AF Micro-Spray Marker**

MANUFACTURING, INC.

Model Shown: MM-12AF

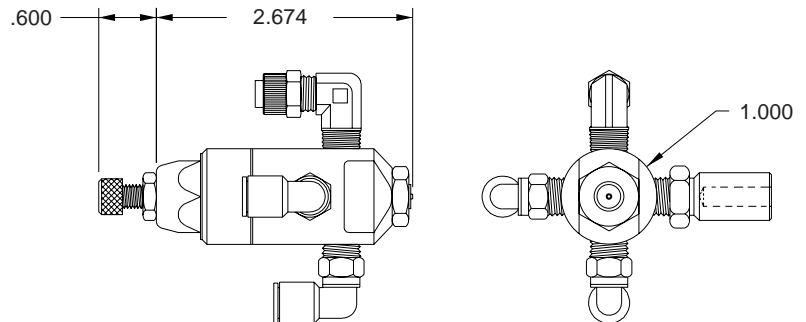

JMD's Micro-Spray Markers are designed for non-contact spot marking applications where color coded dots are required for product identification or acceptance/rejection indication. These low pressure atomizing jet spray marking units can produce up to 180 marks per minute, thus providing a high degree of marking flexibility at typical automation speeds.

Spot or stripe sizes are adjustable from 1/4" minimum to a maximum of 1". These units may be mounted near automation and sensitive test equipment, placed in marking stations on the production line, or attached to robot arms. The Micro-Spray Marker is capable of marking in any attitude and the fast cycle rates make it ideal for high speed marking applications.

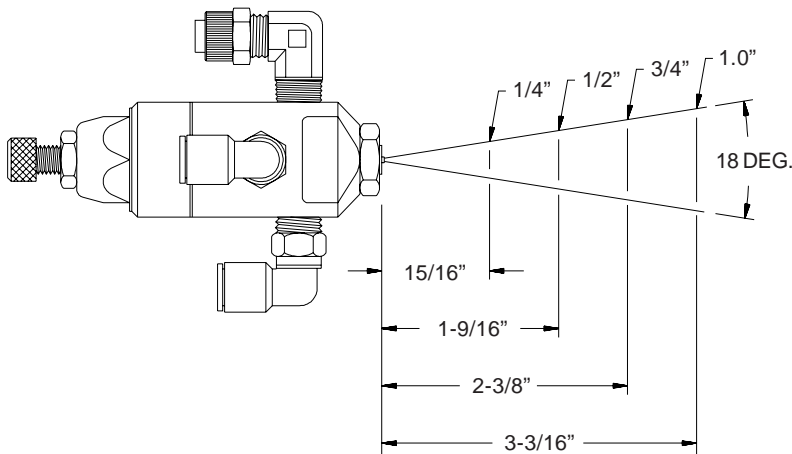

### **Spray Pattern**

The Micro-Spray Marker fires an 18 degree conical spray pattern as shown in the figure to the left. The diameter of the spot or stripe mark being applied depends on the proximity of the target part to the marker nozzle.

A typical Micro-Spray Marker installation includes a MM-12AF Marker, a remote gravity feed ink reservoir, a set of air pressure regulators to supply both the 70-80 psi trigger air and the 5-12 psi atomizing air, and a pair of electrically operated solenoids to activate the spray marking cycle. For spot marking applications, two outputs from a PLC are programmed to control the cycle sequence of the atomizing air and trigger air solenoids. A normal spot mark requires a 100 millisecond pulse signal to the trigger air solenoid.

These markers are capable of using both porous and non-porous, dye or pigment base inks. The self cleaning orifice ensures reliability in both intermittent and continuous duty marking applications. An adjustable fluid control feature regulates the amount of ink flowing into the atomizing air stream providing precise control over the density of the mark.



59 Fountain Street Framingham, MA 01701 USA

Ph: (508) 620-6563 Fax: (508) 620-7563 Website: <http://www.jmdmfg.com>

1-800-752-5JMD (563)